

ENGINE SECTION 3

This service manual has been prepared to provide SUBARU service personnel with the necessary information and data for the correct maintenance and repair of SUBARU vehicles.

This manual includes the procedures for maintenance, disassembling, reassembling, inspection and adjustment of components and diagnostics for guidance of experienced mechanics.

Please peruse and utilize this manual fully to ensure complete repair work for satisfying our customers by keeping their vehicle in optimum condition. When replacement of parts during repair work is needed, be sure to use SUBARU genuine parts.

All information, illustration and specifications contained in this manual are based on the latest product information available at the time of publication approval.

FUEL INJECTION (FUEL SYSTEMS) FU(H4DOSTC)

EMISSION CONTROL (AUX. EMISSION CONTROL DEVICES) EC(H4DOSTC)

INTAKE (INDUCTION) IN(H4DOSTC)

MECHANICAL ME(H4DOSTC)

EXHAUST EX(H4DOSTC)

COOLING CO(H4DOSTC)

LUBRICATION LU(H4DOSTC)

SPEED CONTROL SYSTEMS SP(H4DOSTC)

IGNITION IG(H4DOSTC)

STARTING/CHARGING SYSTEMS SC(H4DOSTC)

ENGINE (DIAGNOSTICS) EN(H4DOSTC)

MECHANICAL

ME(H4DOSTC)

	Page
1. General Description	2
2. Compression	21
3. Idle Speed	22
4. Ignition Timing	23
5. Intake Manifold Vacuum.....	24
6. Engine Oil Pressure	25
7. Fuel Pressure	26
8. Valve Clearance	27
9. Engine Assembly	31
10. Engine Mounting	40
11. Preparation for Overhaul.....	41
12. V-belt.....	42
13. Crankshaft Pulley	44
14. Belt Cover	46
15. Timing Belt Assembly.....	47
16. Camshaft Sprocket.....	55
17. Crankshaft Sprocket.....	56
18. Camshaft.....	57
19. Cylinder Head Assembly	62
20. Cylinder Block	70
21. Engine Trouble in General	90
22. Engine Noise.....	95

16. Camshaft Sprocket

A: REMOVAL

- 1) Remove the V-belt.
<Ref. to ME(H4DOSTC)-42, REMOVAL, V-belt.>
- 2) Remove the crankshaft pulley.
<Ref. to ME(H4DOSTC)-44, REMOVAL, Crankshaft Pulley.>
- 3) Remove the belt cover.
<Ref. to ME(H4DOSTC)-46, REMOVAL, Belt Cover.>
- 4) Remove the timing belt assembly.
<Ref. to ME(H4DOSTC)-47, REMOVAL, Timing Belt Assembly.>
- 5) Remove the camshaft position sensor.
<Ref. to FU(H4DOSTC)-30, REMOVAL, Camshaft Position Sensor.>
- 6) Remove the camshaft sprockets. To lock the camshaft, use ST.

- ST 18231AA010 CAMSHAFT SPROCKET WRENCH (INTAKE LH)
- ST 499207400 CAMSHAFT SPROCKET WRENCH (Except INTAKE LH)

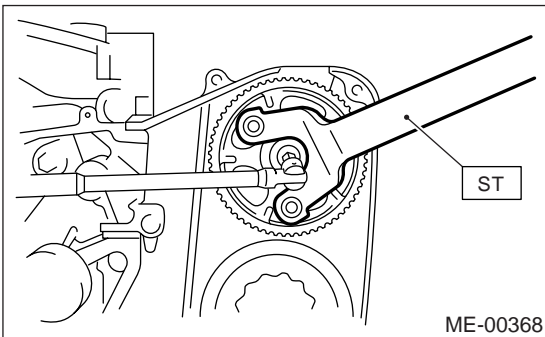

B: INSTALLATION

- 1) Install the camshaft sprocket. To lock the camshaft, use ST.

- ST 18231AA010 CAMSHAFT SPROCKET WRENCH (INTAKE LH)
- ST 499207400 CAMSHAFT SPROCKET WRENCH (Except INTAKE LH)

Tightening torque:

98 N·m (10 kgf·m, 72.4 ft·lb)

NOTE:

Do not confuse the right and left side camshaft sprockets intake side during installation. The cam-

shaft sprocket LH is identified by a projection used to monitor camshaft position sensor.

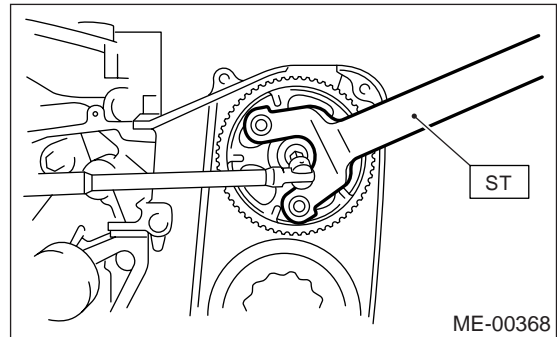

- 2) Install the camshaft position sensor.
<Ref. to FU(H4DOSTC)-30, INSTALLATION, Camshaft Position Sensor.>
- 3) Install the timing belt assembly.
<Ref. to ME(H4DOSTC)-49, INSTALLATION, Timing Belt Assembly.>
- 4) Install the belt cover.
<Ref. to ME(H4DOSTC)-46, INSTALLATION, Belt Cover.>
- 5) Install the crankshaft pulley.
<Ref. to ME(H4DOSTC)-44, INSTALLATION, Crankshaft Pulley.>
- 6) Install the V-belt.
<Ref. to ME(H4DOSTC)-42, INSTALLATION, V-belt.>

C: INSPECTION

- 1) Check the sprocket teeth for abnormal wear and scratches.
- 2) Make sure there is no free play between sprocket and key.
- 3) Check the crankshaft sprocket notch used for sensor for damage and contamination of foreign matter.

CRANKSHAFT SPROCKET

MECHANICAL

17.Crankshaft Sprocket

A: REMOVAL

- 1) Remove the V-belt.
<Ref. to ME(H4DOSTC)-42, REMOVAL, V-belt.>
- 2) Remove the crankshaft pulley.
<Ref. to ME(H4DOSTC)-44, REMOVAL, Crankshaft Pulley.>
- 3) Remove the belt cover.
<Ref. to ME(H4DOSTC)-46, REMOVAL, Belt Cover.>
- 4) Remove the timing belt assembly.
<Ref. to ME(H4DOSTC)-47, REMOVAL, Timing Belt Assembly.>
- 5) Remove the camshaft sprocket.
<Ref. to ME(H4DOSTC)-55, REMOVAL, Camshaft Sprocket.>
- 6) Remove the crankshaft sprocket.

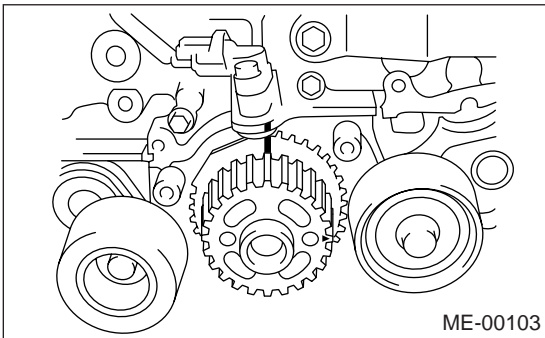

B: INSTALLATION

- 1) Install the crankshaft sprocket.

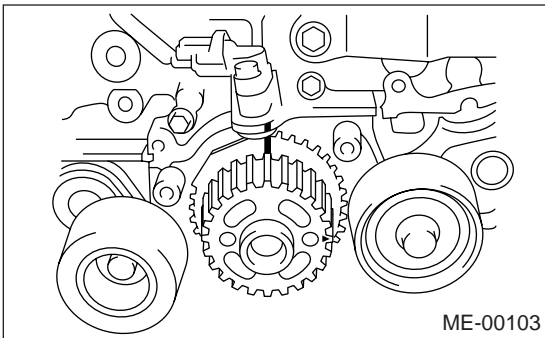

- 2) Install the camshaft sprocket.
<Ref. to ME(H4DOSTC)-55, INSTALLATION, Camshaft Sprocket.>
- 3) Install the timing belt assembly.
<Ref. to ME(H4DOSTC)-49, INSTALLATION, Timing Belt Assembly.>
- 4) Install the belt cover.
<Ref. to ME(H4DOSTC)-46, INSTALLATION, Belt Cover.>
- 5) Install the crankshaft pulley.
<Ref. to ME(H4DOSTC)-44, INSTALLATION, Crankshaft Pulley.>

- 6) Install the V-belt.

<Ref. to ME(H4DOSTC)-42, INSTALLATION, V-belt.>

C: INSPECTION

- 1) Check the sprocket teeth for abnormal wear and scratches.
- 2) Make sure there is no free play between sprocket and key.
- 3) Check the crankshaft sprocket notch used for sensor for damage and contamination of foreign matter.

18. Camshaft

A: REMOVAL

- 1) Remove the V-belt.
<Ref. to ME(H4DOSTC)-42, REMOVAL, V-belt.>
- 2) Remove the crankshaft pulley.
<Ref. to ME(H4DOSTC)-44, REMOVAL, Crankshaft Pulley.>
- 3) Remove the belt cover.
<Ref. to ME(H4DOSTC)-46, REMOVAL, Belt Cover.>
- 4) Remove the timing belt assembly.
<Ref. to ME(H4DOSTC)-47, REMOVAL, Timing Belt Assembly.>
- 5) Remove the camshaft sprocket.
<Ref. to ME(H4DOSTC)-55, REMOVAL, Camshaft Sprocket.>
- 6) Remove the crankshaft sprocket.
<Ref. to ME(H4DOSTC)-56, REMOVAL, Crankshaft Sprocket.>
- 7) Remove the tensioner bracket.

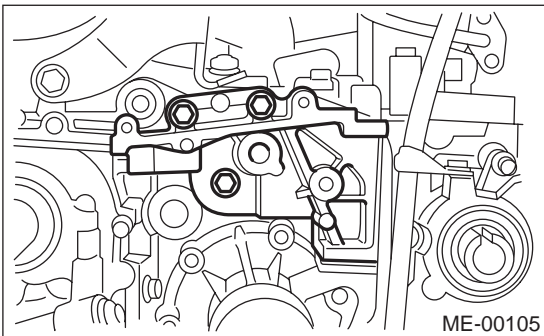

- 8) Remove the belt cover No. 2 (LH).

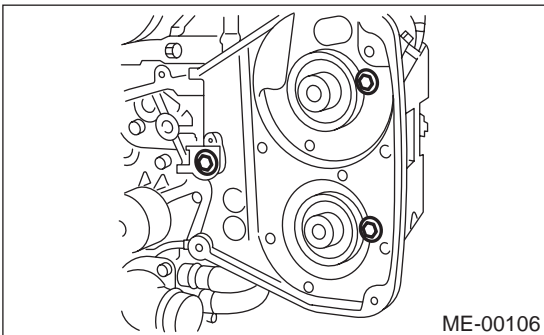

- 9) Remove the belt cover No. 2 (RH).

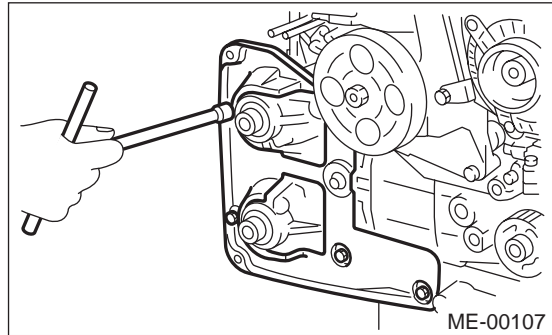

- 10) Disconnect the ignition coil connector.
- 11) Remove the ignition coil.
- 12) Remove the rocker cover and gasket.
- 13) Loosen the intake camshaft cap bolts equally, a little at a time in alphabetical sequence shown in the figure.

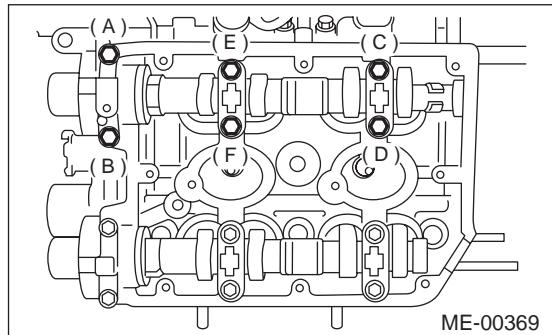

- 14) Remove the camshaft cap and intake camshaft.
- 15) Loosen the exhaust camshaft cap bolts equally, a little at a time in alphabetical sequence shown in the figure.

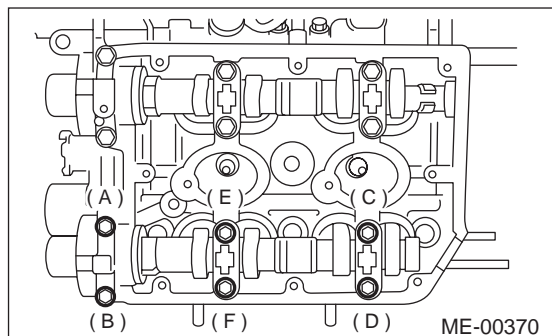

- 16) Remove the camshaft caps and exhaust camshaft.

NOTE:

Arrange the camshaft caps in order so that they can be installed in their original positions.

- 17) Similarly, remove the camshafts (RH) and related parts.

CAMSHAFT

MECHANICAL

B: INSTALLATION

1) Camshaft installation:

Apply engine oil to the cylinder head at camshaft bearing location before installing the camshaft. Install the camshaft so that each valves is close to or in contact with "base circle" of cam lobe.

NOTE:

- When the camshafts are positioned as shown in the figure, camshafts need to be rotated at a minimum to align with the timing belt during installation.
- Camshaft (RH) need not be rotated when set at the position shown in the figure.

Intake camshaft (LH): Rotate 80° clockwise.

Exhaust camshaft (LH): Rotate 45° counterclockwise.

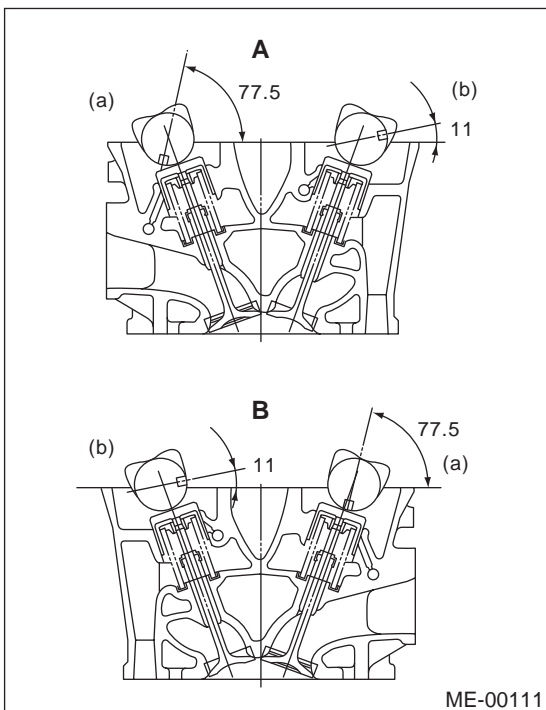

- A Left side cylinder head
- B Right side cylinder head
- (a) Intake camshaft
- (b) Exhaust camshaft

2) Camshaft cap installation:

- (1) Apply fluid packing sparingly to the cap mating surface.

NOTE:

Do not apply fluid packing excessively. Failure to do so may cause excess packing to come out and flow toward oil seal, resulting in oil leaks.

Fluid packing:

Part No. 004403007

THREE BOND 1215 or equivalent

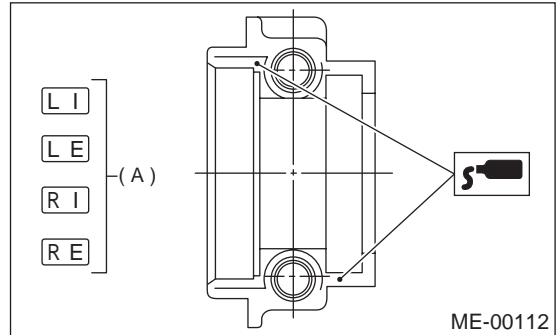

- (2) Apply engine oil to cap bearing surface and install the cap on camshaft as shown by identification mark (A).

- (3) Gradually tighten the camshaft cap in at least two stages in alphabetical sequence shown in the figure, and then tighten to specified torque.

Tightening torque:

T1: 10 N·m (1.0 kgf·m, 7.2 ft·lb)

T2: 20 N·m (2.0 kgf·m, 14.5 ft·lb)

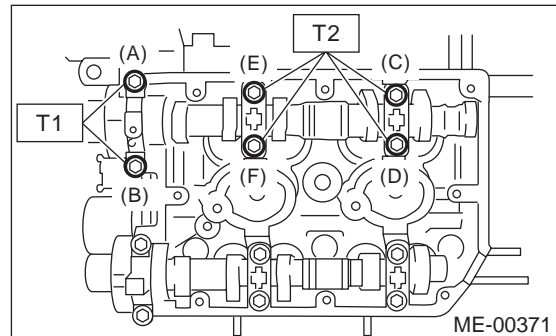

- (4) Similarly, tighten the cap on exhaust side. After tightening the cap, ensure the camshaft rotates only slightly while holding it at "base" circle.

Tightening torque:

T1: 10 N·m (1.0 kgf·m, 7.2 ft·lb)

T2: 20 N·m (2.0 kgf·m, 14.5 ft·lb)

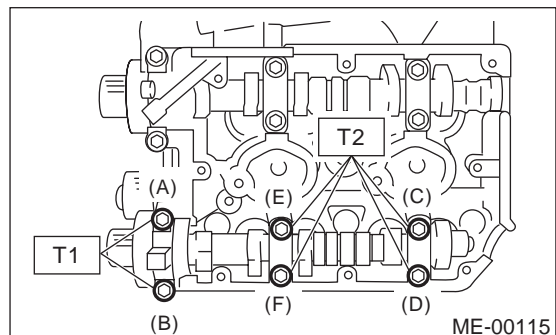

3) Camshaft oil seal installation:
Apply grease to the new oil seal lips and press onto the front end of camshaft by using ST1 and ST2.

NOTE:

Use a new oil seal.

ST1	499587600	OIL SEAL INSTALLER
ST2	499597200	OIL SEAL GUIDE

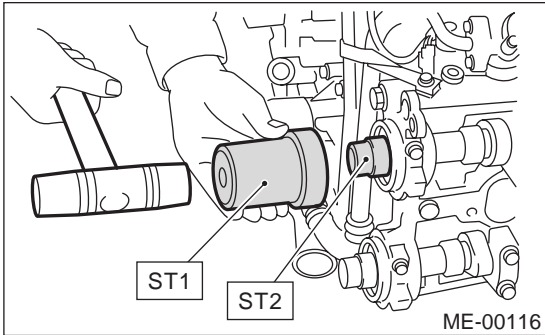

4) Rocker cover installation:
(1) Install the gasket on rocker cover.
Install the peripheral gasket and ignition coil gasket.
(2) Apply fluid packing to the indicated portion on rocker cover.

Fluid packing:

Part No. 004403007

THREE BOND 1215 or equivalent

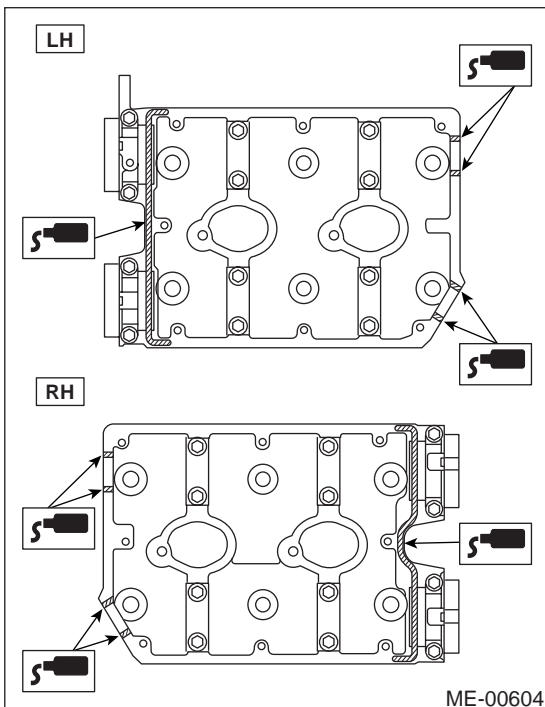

(3) Install the rocker cover on cylinder head.
Ensure the gasket is properly positioned during installation.
5) Install the ignition coil.
6) Connect the ignition coil connector.

7) Similarly, install the parts on right-hand side.
8) Install the belt cover No. 2 (RH).

Tightening torque:

5 N·m (0.5 kgf·m, 3.6 ft·lb)

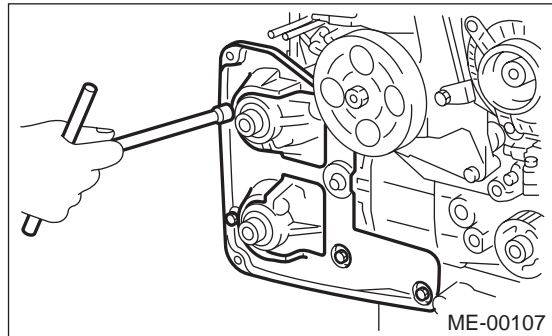

9) Install the tensioner bracket.

Tightening torque:

25 N·m (2.5 kgf·m, 18.1 ft·lb)

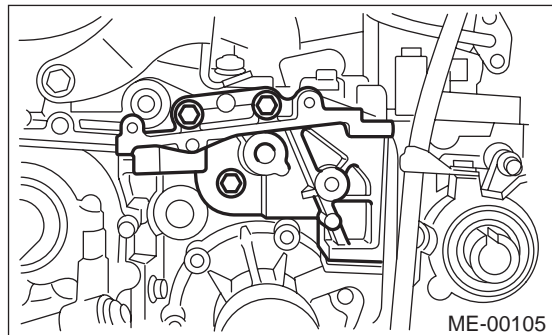

10) Install the belt cover No. 2 (LH).

Tightening torque:

5 N·m (0.5 kgf·m, 3.6 ft·lb)

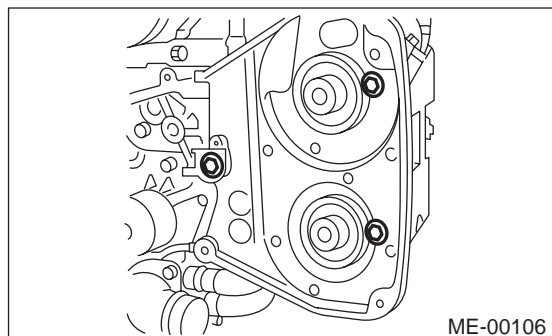

11) Install the crankshaft sprockets.
<Ref. to ME(H4DOSTC)-56, INSTALLATION, Crankshaft Sprocket.>
12) Install the camshaft sprocket.
<Ref. to ME(H4DOSTC)-55, INSTALLATION, Camshaft Sprocket.>
13) Install the timing belt assembly.
<Ref. to ME(H4DOSTC)-49, INSTALLATION, Timing Belt Assembly.>
14) Install the belt cover.

CAMSHAFT

MECHANICAL

<Ref. to ME(H4DOSTC)-46, INSTALLATION, Belt Cover.>

15) Install the crankshaft pulley.

<Ref. to ME(H4DOSTC)-44, INSTALLATION, Crankshaft Pulley.>

16) Install the V-belt.

<Ref. to ME(H4DOSTC)-42, INSTALLATION, V-belt.>

C: INSPECTION

1) Measure the bend, and repair or replace if necessary.

Limit:

0.020 mm (0.0008 in)

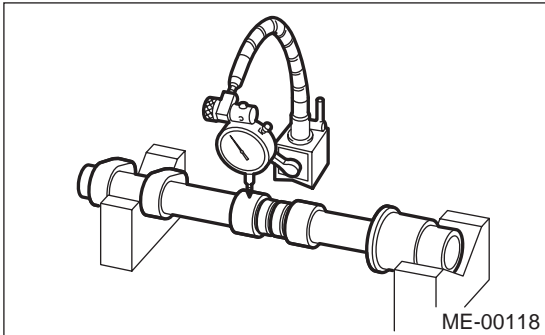

2) Check the journal for damage and wear. Replace if faulty.

3) Measure the outside diameter of camshaft journal. If the journal diameter is not as specified, check the oil clearance.

	Camshaft journal	
	Front	Center, rear
Standard	37.946 — 37.963 mm (1.4939 — 1.4946 in)	29.946 — 29.963 mm (1.1790 — 1.1796 in)

4) Measurement of the camshaft journal oil clearance:

(1) Clean the bearing caps and camshaft journals.

(2) Place the camshafts on cylinder head. (Without installing the valve rocker.)

(3) Place a plastigauge across each of the camshaft journals.

(4) Gradually tighten the cap in at least two stages in alphabetical sequence shown in the figure, and then tighten to specified torque.

Do not turn the camshaft.

Tightening torque:

T1: 10 N·m (1.0 kgf·m, 7.2 ft·lb)

T2: 20 N·m (2.0 kgf·m, 14.5 ft·lb)

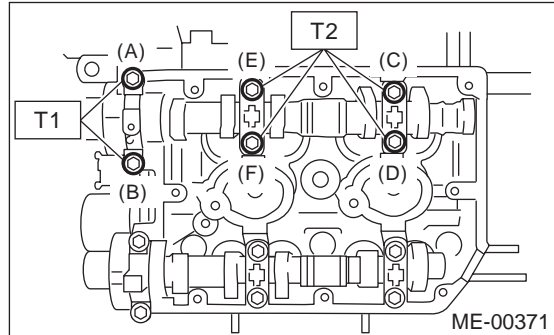

(5) Remove the bearing caps.

(6) Measure the widest point of plastigauge on each journal.

If the oil clearance exceeds the limit, replace the camshaft. If necessary, replace the camshaft caps and cylinder head as a set.

Standard:

0.037 — 0.072 mm (0.0015 — 0.0028 in)

Limit:

0.10 mm (0.0039 in)

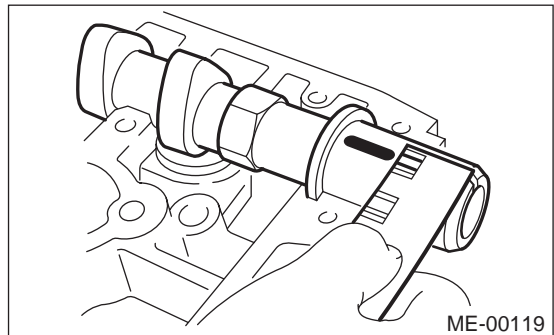

(7) Completely remove the plastigauge.

5) Check the cam face condition; remove the minor faults by grinding with oil stone. Measure the cam height H; replace if the limit has been exceeded.

Cam height: H

Standard:

Intake:

46.25 — 46.35 mm (1.821 — 1.825 in)

Exhaust:

46.15 — 46.25 mm (1.817 — 1.821 in)

Limit:

Intake:

46.15 mm (1.817 in)

Exhaust:

46.65 mm (1.813 in)

Cam base circle diameter A:
37.0 mm (1.457 in)

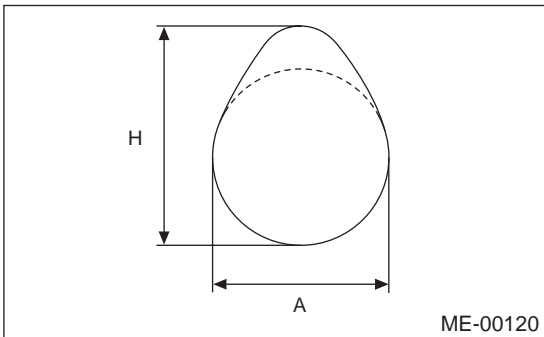

6) Measure the thrust clearance of camshaft with dial gauge. If the clearance exceeds the limit, replace the caps and cylinder head as a set. If necessary replace the camshaft.

Standard:

0.015 — 0.070 mm (0.0006 — 0.0028 in)

Limit:

0.1 mm (0.004 in)

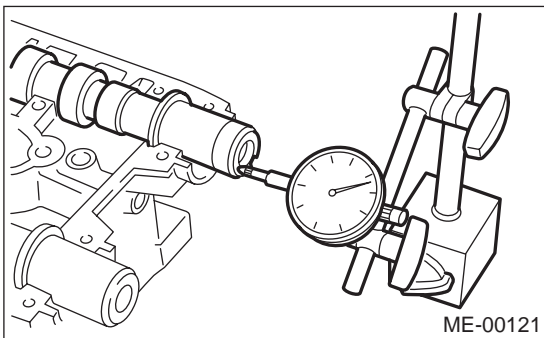

CYLINDER HEAD ASSEMBLY

MECHANICAL

19. Cylinder Head Assembly

A: REMOVAL

- 1) Remove the V-belt.
<Ref. to ME(H4DOSTC)-42, REMOVAL, V-belt.>
- 2) Remove the crankshaft pulley.
<Ref. to ME(H4DOSTC)-44, REMOVAL, Crankshaft Pulley.>
- 3) Remove the belt cover.
<Ref. to ME(H4DOSTC)-46, REMOVAL, Belt Cover.>
- 4) Remove the timing belt assembly.
<Ref. to ME(H4DOSTC)-47, REMOVAL, Timing Belt Assembly.>
- 5) Remove the camshaft sprocket.
<Ref. to ME(H4DOSTC)-55, REMOVAL, Camshaft Sprocket.>
- 6) Remove the intake manifold.
<Ref. to FU(H4DOSTC)-15, REMOVAL, Intake Manifold.>
- 7) Remove the bolt which installs A/C compressor bracket on cylinder head.
- 8) Remove the camshaft. <Ref. to ME(H4DOSTC)-57, REMOVAL, Camshaft.>
- 9) Remove the cylinder head bolts in alphabetical sequence shown in the figure.
Leave bolts (A) and (D) engaged by three or four threads to prevent the cylinder head from falling.

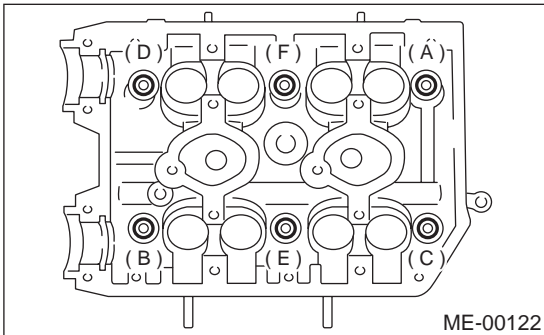

- 10) While tapping the cylinder head with a plastic hammer, separate it from cylinder block.
Remove the bolts (A) and (D) to remove cylinder head.

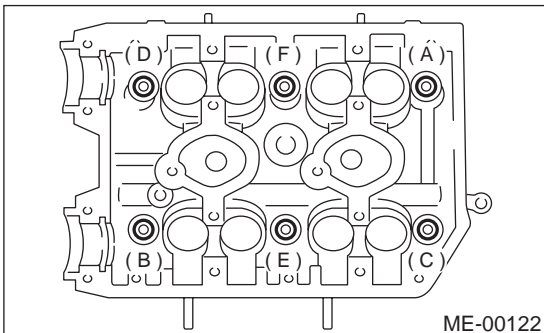

- 11) Remove the cylinder head gasket.

NOTE:

Do not scratch the mating surface of cylinder head and cylinder block.

- 12) Similarly, remove the right side cylinder head.

B: INSTALLATION

- 1) Install the cylinder head and gaskets on cylinder block.

NOTE:

- Use new cylinder head gaskets.
 - Be careful not to scratch the mating surface of cylinder head and cylinder block.
- 2) Tighten the cylinder head bolts.
 - (1) Apply a coat of engine oil to the washers and bolt threads.
 - (2) Tighten all bolts to 29 N·m (3.0 kgf-m, 22 ft-lb) in alphabetical sequence.
 - (3) Tighten all bolts to 69 N·m (7.0 kgf-m, 51 ft-lb) in alphabetical sequence again.
 - (4) Back off all bolts by 180° first; back them off by 180° again in reverse order of installation.
 - (5) Tighten all bolts to 39 N·m (4.0 kgf-m, 29 ft-lb) in alphabetical sequence.
 - (6) Tighten all bolts 80 to 90° in alphabetical sequence.
 - (7) Tighten all bolts by 40 to 45° in alphabetical sequence again.

NOTE:

Do not tighten the bolts by more than 45°.

- (8) Further tighten all bolts (A) and (B) by 40 to 45°.

NOTE:

Ensure that the total “re-tightening angle” in the previous two steps do not exceed 90°.

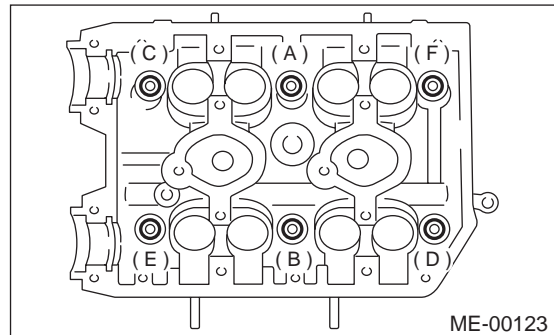

- 3) Install the camshaft.
<Ref. to ME(H4DOSTC)-58, INSTALLATION, Camshaft.>
- 4) Install the A/C compressor bracket on cylinder head.
- 5) Install the intake manifold.
<Ref. to FU(H4DOSTC)-18, INSTALLATION, Intake Manifold.>

- 6) Install the camshaft sprocket.
<Ref. to ME(H4DOSTC)-55, INSTALLATION, Camshaft Sprocket.>
- 7) Install the timing belt assembly.
<Ref. to ME(H4DOSTC)-49, INSTALLATION, Timing Belt Assembly.>
- 8) Install the belt cover.
<Ref. to ME(H4DOSTC)-46, INSTALLATION, Belt Cover.>
- 9) Install the crankshaft pulley.
<Ref. to ME(H4DOSTC)-44, INSTALLATION, Crankshaft Pulley.>
- 10) Install the V-belt.
<Ref. to ME(H4DOSTC)-42, INSTALLATION, V-belt.>

C: DISASSEMBLY

- 1) Remove the valve shims and valve lifters.
- 2) Compress the valve spring and remove the valve spring retainer key. Remove each valve and valve spring.

ST1 498267600 CYLINDER HEAD TABLE
ST2 499718000 VALVE SPRING REMOVER

NOTE:

- Keep the removed parts in order for re-installing in their original positions.
- Mark each valve to prevent confusion.
- Use extreme care not to damage the lips of the intake valve oil seals and exhaust valve oil seals.

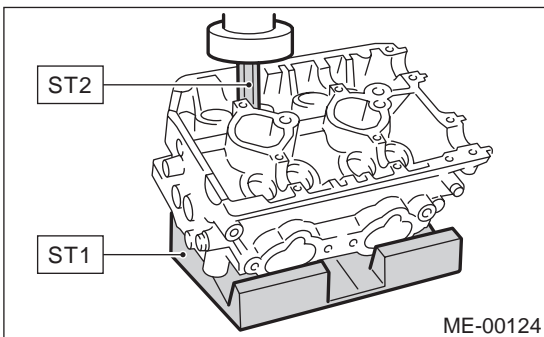

CYLINDER HEAD ASSEMBLY

MECHANICAL

D: ASSEMBLY

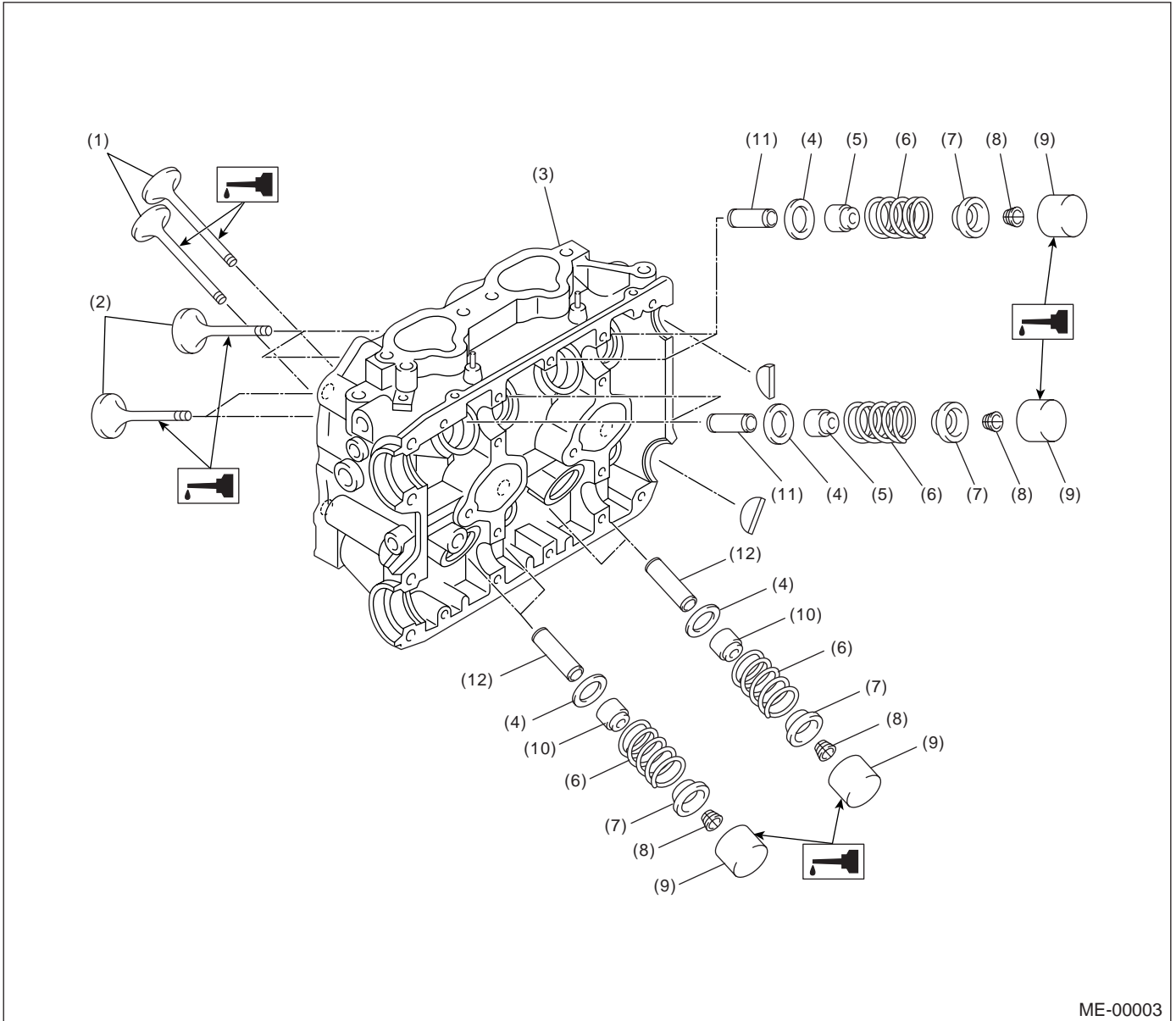

ME-00003

- | | | |
|-----------------------|---------------------------|-----------------------------|
| (1) Exhaust valve | (5) Intake valve oil seal | (9) Valve lifter |
| (2) Intake valve | (6) Valve spring | (10) Exhaust valve oil seal |
| (3) Cylinder head | (7) Retainer | (11) Intake valve guide |
| (4) Valve spring seat | (8) Retainer key | (12) Exhaust valve guide |

- 1) Installation of valve spring and valve:
 - (1) Coat the stem of each valve with engine oil and insert the valve into valve guide.

NOTE:

When inserting the valve into valve guide, use special care not to damage the oil seal lip.

- (2) Set the cylinder head on ST1.
- (3) Install the valve spring and retainer using ST2.

ST1 498267600 CYLINDER HEAD TABLE
 ST2 499718000 VALVE SPRING REMOVER

NOTE:

Be sure to install the valve springs with their close-coiled end facing the seat on the cylinder head.

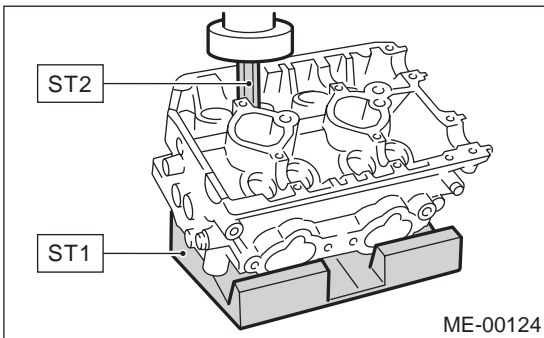

- (4) Compress the valve spring, and then fit the valve spring retainer key.
 - (5) After installing, tap the valve spring retainers lightly with wooden hammer for better seating.
- 2) Apply oil to the surface of the valve lifter.
 - 3) Install the valve lifter.

E: INSPECTION

1. CYLINDER HEAD

- 1) Make sure that no crack or other damage exists. In addition to visual inspection, inspect the important areas by means of red check.
- 2) Measure the warping of the cylinder head surface that mates with crankcase by using a straight edge (A) and thickness gauge (B). If the warping exceeds 0.05 mm (0.0020 in), re-grind the surface with a surface grinder.

Warping limit:
 0.05 mm (0.0020 in)

Grinding limit:
 0.3 mm (0.012 in)

Standard height of cylinder head:
 127.5 mm (5.02 in)

NOTE:

Uneven torque for the cylinder head nuts can cause warping. When reassembling, pay special attention to the torque so as to tighten evenly.

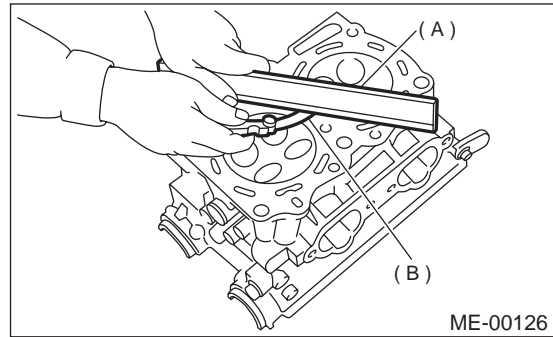

2. VALVE SEAT

Inspect the intake and exhaust valve seats, and then correct the contact surfaces with valve seat cutter if they are defective or when valve guides are replaced.

Valve seat width: W

Intake

Standard
 1.0 mm (0.039 in)

Limit
 1.7 mm (0.067 in)

Exhaust

Standard
 1.5 mm (0.059 in)

Limit
 2.2 mm (0.087 in)

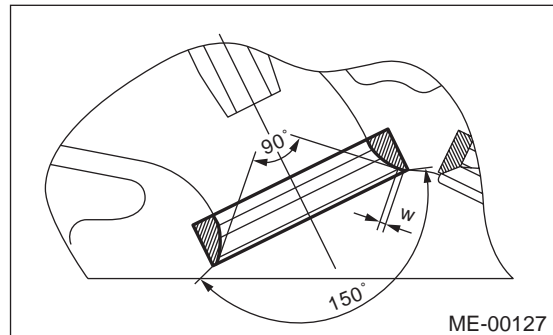

CYLINDER HEAD ASSEMBLY

MECHANICAL

3. VALVE GUIDE

1) Check the clearance between valve guide and stem. The clearance can be checked by measuring the outside diameter of valve stem and the inside diameter of valve guide with outside and inside micrometers respectively.

Clearance between the valve guide and valve stem:

Standard

Intake

0.030 — 0.057 mm (0.0012 — 0.0022 in)

Exhaust

0.040 — 0.067 mm (0.0016 — 0.0026 in)

Limit

0.15 mm (0.0059 in)

2) If the clearance between valve guide and stem exceeds the limit, replace the valve guide or valve itself whichever shows greater amount of wear. See the following procedure for valve guide replacement.

Valve guide inner diameter:

6.000 — 6.012 mm (0.2362 — 0.2367 in)

Valve stem outer diameters:

Intake

5.955 — 5.970 mm (0.2344 — 0.2350 in)

Exhaust

5.945 — 5.960 mm (0.2341 — 0.2346 in)

(1) Place the cylinder head on ST1 with the combustion chamber upward so that valve guides enter the holes in ST1.

(2) Insert the ST2 into valve guide and press it down to remove the valve guide.

ST1 498267600 CYLINDER HEAD TABLE
ST2 499767200 VALVE GUIDE REMOVER

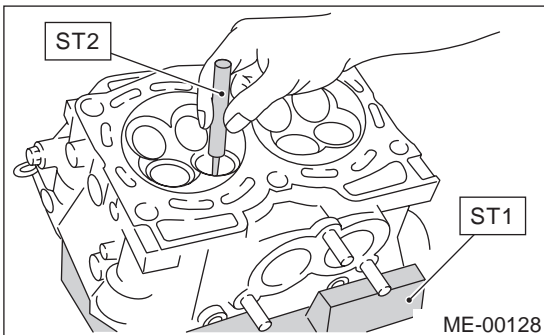

(3) Turn the cylinder head upside down and place ST as shown in the figure.

ST 18251AA020 VALVE GUIDE ADJUSTER

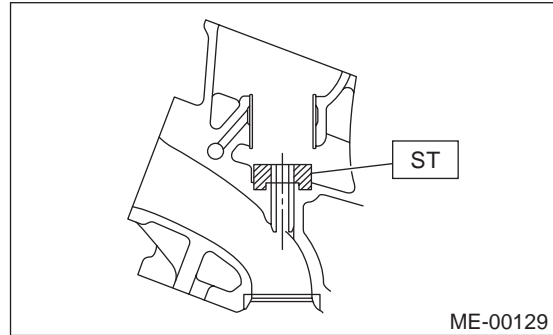

(4) Before installing a new valve guide, make sure that neither scratches nor damages exist on the inside surface of the valve guide holes in cylinder head.

(5) Put a new valve guide, coated with sufficient oil, in cylinder, and insert ST1 into valve guide. Press in until the valve guide upper end is flush with the upper surface of ST2.

ST1 499767200 VALVE GUIDE REMOVER
ST2 18251AA020 VALVE GUIDE ADJUSTER

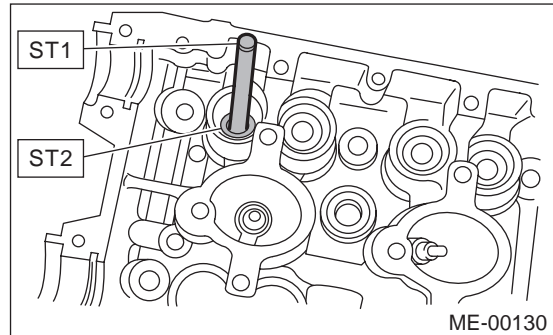

(6) Check the valve guide protrusion.

Valve guide protrusion: L

15.8 — 16.2 mm (0.622 — 0.638 in)

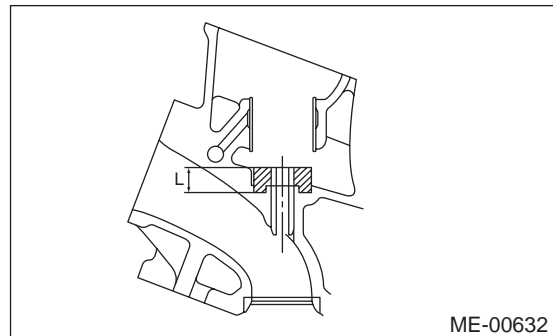

(7) Ream the inside of valve guide with ST. Gently rotate the reamer clockwise while pressing it lightly into the valve guide, and return it also rotating clockwise. After reaming, clean the valve guide to remove chips.

ST 499767400 VALVE GUIDE REAMER

NOTE:

- Apply engine oil to the reamer when reaming.
- If the inner surface of the valve guide is torn, the edge of the reamer should be slightly ground with an oil stone.
- If the inner surface of the valve guide becomes lustrous and the reamer does not chips, use a new reamer or remedy the reamer.

(8) Recheck the contact condition between valve and valve seat after replacing the valve guide.

4. INTAKE AND EXHAUST VALVE

1) Inspect the flange and stem of valve, and replace if damaged, worn, or deformed, or if "H" is less than the specified limit.

H:

Intake

Standard

1.2 mm (0.047 in)

Limit

0.8 mm (0.031 in)

Exhaust

Standard

1.5 mm (0.059 in)

Limit

0.8 mm (0.031 in)

Valve overall length:

Intake

104.4 mm (4.110 in)

Exhaust

104.7 mm (4.122 in)

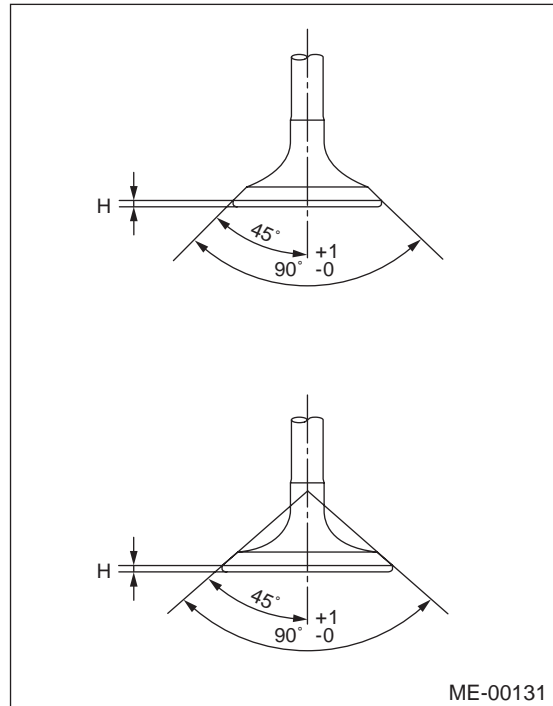

2) Put a small amount of grinding compound on the seat surface and lap the valve and seat surface. Install a new intake valve oil seal after lapping.

CYLINDER HEAD ASSEMBLY

MECHANICAL

5. VALVE SPRINGS

- 1) Check the valve springs for damage, free length, and tension. Replace the valve spring if it is not within specifications presented in the table.
- 2) To measure the squareness of valve spring, stand the spring on a surface plate and measure its deflection at the top using a try square.

	Valve spring
Free length	44.67 mm (1.7587 in)
Tension/spring height	206 — 236 N (21.0 — 24.1 kgf, 46.2 — 53.1 lb) /36.0 mm (1.417 in)
	485 — 537 N (49.5 — 54.8 kgf, 109.2 — 120.6 lb) /26.6 mm (1.047 in)
Squareness	2.5°, 2.0 mm (0.079 in)

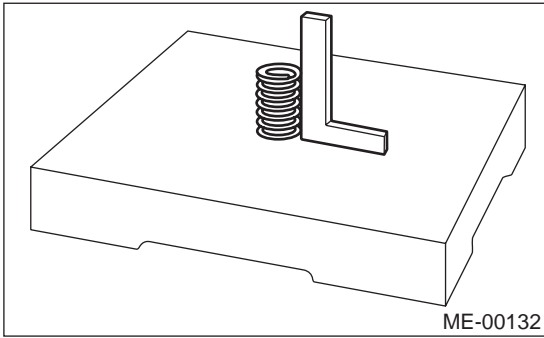

6. INTAKE AND EXHAUST VALVE OIL SEAL

Replace the oil seal with a new one, if the lip is damaged or spring out of place, or when the surfaces of intake valve and valve seat are reconditioned or intake valve guide is replaced.

- 1) Place the cylinder head on ST1.
- 2) Press in the oil seal as shown in the figure by using ST2.

ST1 498267600 CYLINDER HEAD TABLE
ST2 498857100 VALVE OIL SEAL GUIDE

NOTE:

- Apply engine oil to oil seal before force-fitting.
- Differentiate between the intake valve oil seal and exhaust valve oil seal by noting their difference in color.

Color of rubber part:
Intake [Black]
Exhaust [Brown]

Color of spring part:
Intake [Silver]
Exhaust [Silver]

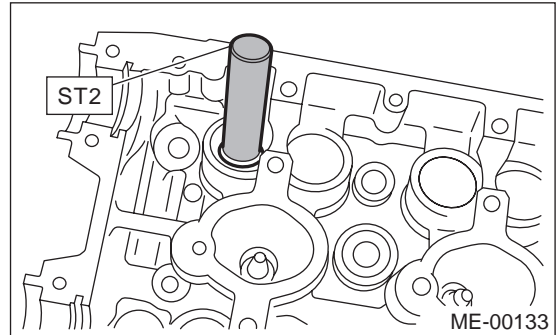

7. VALVE LIFTER

- 1) Check the valve lifter visually.
- 2) Measure the outer diameter of valve lifter.

Outer diameter:

34.959 — 34.975 mm (1.3763 — 1.3770 in)

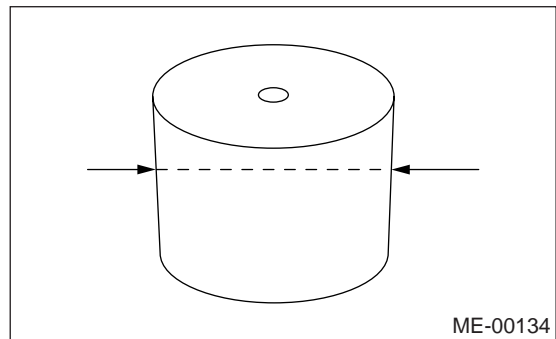

- 3) Measure the inner diameter of valve lifter mating part on cylinder head.

Inner diameter:

34.994 — 35.016 mm (1.3777 — 1.3786 in)

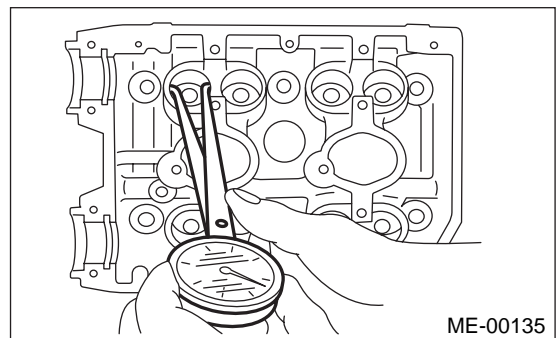

NOTE:

If difference between outer diameter of valve lifter and inner diameter of valve lifter mating part is over the limit, replace the cylinder head.

Standard:

0.019 — 0.057 mm (0.0007 — 0.0022 in)

Limit:

0.100 mm (0.0039 in)

F: DISPOSAL**CAUTION:**

• **Metallic sodium is enclosed in the exhaust valve. Metallic sodium is extremely alkaline and may produce severe chemical reactions. Full consideration must therefore be given to the following points when handing or disposing of the valve.**

• **Since metallic sodium may cause blindness if contacted with the eyes, burns if contacted with the skin, and fire, do not deliberately take the valve apart and remove the metallic sodium.**

1) If the valve is damaged, remove the valve and neutralize it by immersing it in water, and dispose of it in the same way that general steel materials are disposed of. The disposal method is described in the following.

(1) Wearing rubber gloves, remove the damaged valve from the cylinder head.

(2) Prepare a large receptacle (bucket or other container) in a well ventilated location, and fill the receptacle with water (at least 10 liters).

(3) Immerse the damaged valve in the receptacle.

CAUTION:

A severe reaction may occur, so stand at least 2 — 3 m from the receptacle. Because the reaction will produce hydrogen gas, moreover, keep the receptacle away from sparks or flames.

(4) Once the reaction is completed (about 4 — 5 hours have elapsed), carefully remove the valve using large pincers so that the reaction liquid does not contact your skin, and dispose of it with other parts that are being disposed of.

(5) The reaction liquid is a strong alkaline solution, so it must be disposed of in accordance with local regulations.

CAUTION:

Make sure the reaction liquid does not contact your skin. If contact with skin occurs, immediately wash the affected area with large quantities of water.

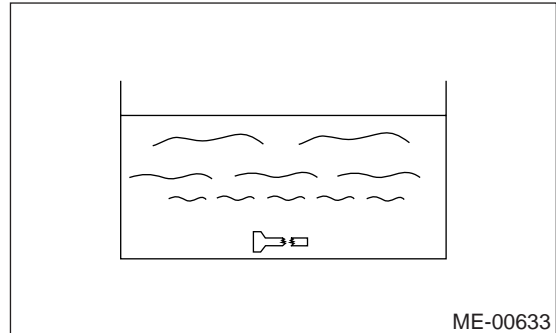

CYLINDER BLOCK

MECHANICAL

20. Cylinder Block

A: REMOVAL

NOTE:

Before conducting this procedure, drain the engine oil completely if applicable.

- 1) Remove the intake manifold.
<Ref. to FU(H4DOSTC)-15, REMOVAL, Intake Manifold.>
- 2) Remove the V-belt. <Ref. to ME(H4DOSTC)-42, REMOVAL, V-belt.>
- 3) Remove the crankshaft pulley.
<Ref. to ME(H4DOSTC)-44, REMOVAL, Crankshaft Pulley.>
- 4) Remove the belt cover.
<Ref. to ME(H4DOSTC)-46, REMOVAL, Belt Cover.>
- 5) Remove the timing belt assembly.
<Ref. to ME(H4DOSTC)-47, REMOVAL, Timing Belt Assembly.>
- 6) Remove the camshaft sprocket.
<Ref. to ME(H4DOSTC)-55, REMOVAL, Camshaft Sprocket.>
- 7) Remove the crankshaft sprocket.
<Ref. to ME(H4DOSTC)-56, REMOVAL, Crankshaft Sprocket.>
- 8) Remove the generator and A/C compressor with their brackets.
- 9) Remove the cylinder head assembly.
<Ref. to ME(H4DOSTC)-62, REMOVAL, Cylinder Head Assembly.>
- 10) Remove the clutch disc and cover. (MT vehicles) <Ref. to CL-15, REMOVAL, Clutch Disc and Cover.>
- 11) Remove the flywheel. (MT vehicles)
<Ref. to CL-20, REMOVAL, Flywheel.>
- 12) Remove the drive plate. (AT vehicles)
Using the ST, lock crankshaft.

ST 498497100 CRANKSHAFT STOPPER

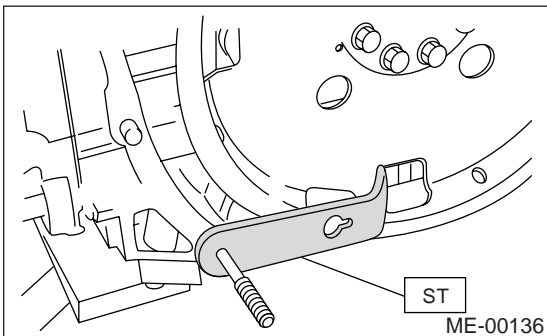

- 13) Remove the oil separator cover.
- 14) Remove the water by-pass pipe for heater.
- 15) Remove the oil filter.

- 16) Remove the oil cooler. (MT vehicles)

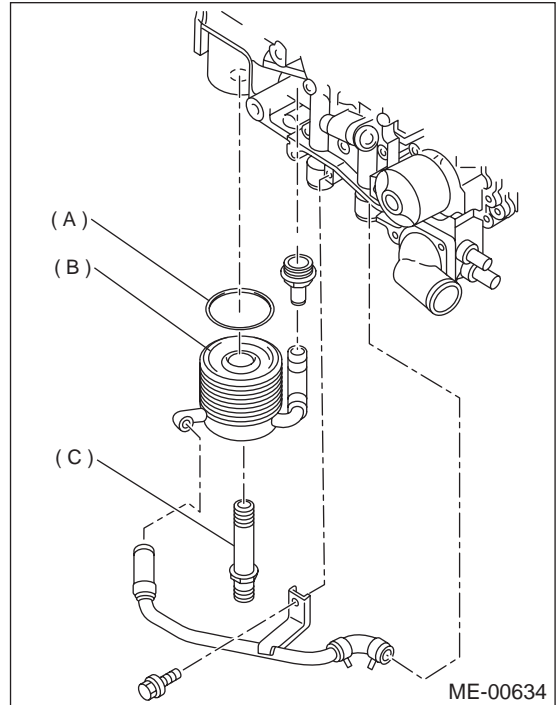

- (A) Gasket
- (B) Oil cooler
- (C) Oil cooler connector

- 17) Removal of oil pan:

- (1) Turn the cylinder block with #2 and #4 piston sides facing upward.
- (2) Remove the bolts which secure oil pan to cylinder block.
- (3) Insert an oil pan cutter blade between cylinder block-to-oil pan clearance, and then remove the oil pan.

Do not use a screwdriver or similar tool in place of oil pan cutter.

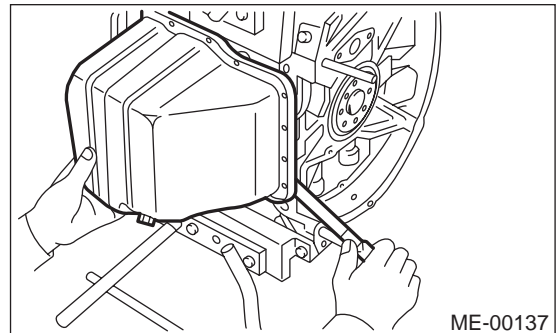

- 18) Remove the oil strainer stay.
- 19) Remove the oil strainer.
- 20) Remove the baffle plate.
- 21) Remove the water pipes.
- 22) Remove the water pump.

CYLINDER BLOCK

MECHANICAL

23) Remove the oil pump from cylinder block.
Use a flat-bladed screwdriver as shown in the figure when removing the oil pump.

NOTE:
Be careful not to scratch the mating surface of cylinder block and oil pump.

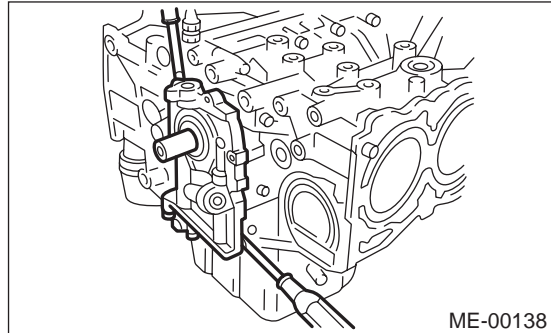

ME-00138

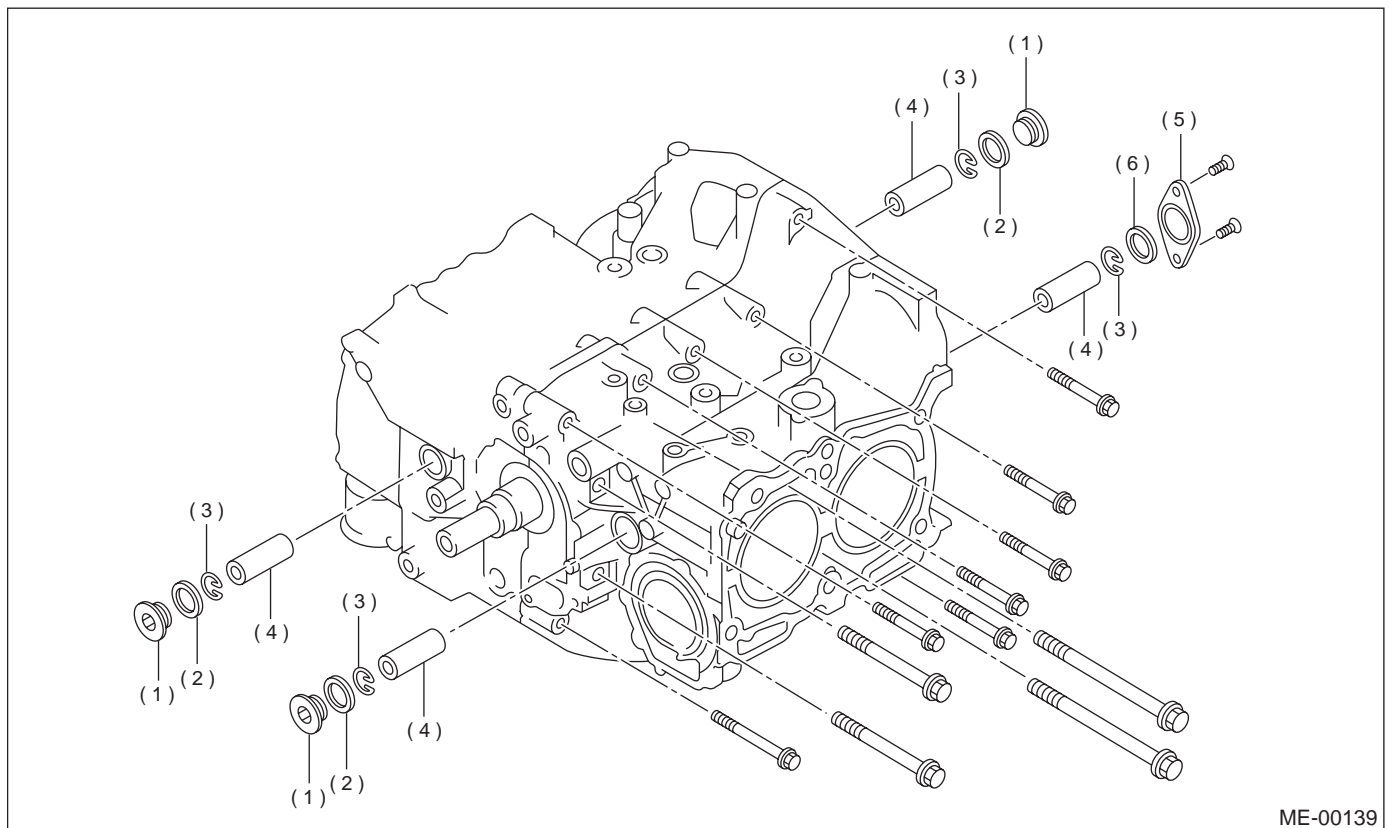

ME-00139

(1) Service hole plug
(2) Gasket

(3) Circlip
(4) Piston pin

(5) Service hole cover
(6) O-ring

CYLINDER BLOCK

MECHANICAL

24) Remove the service hole cover and service hole plugs using hexagon wrench [14 mm (0.55 in)].

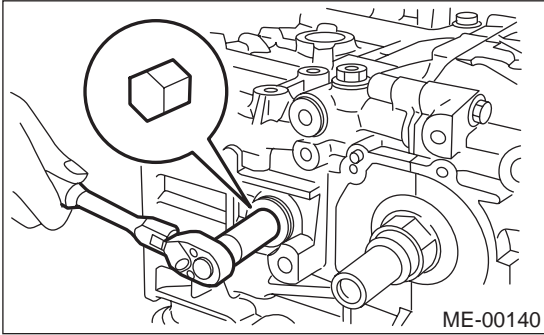

25) Rotate the crankshaft to bring #1 and #2 pistons to bottom dead center position, and then remove the piston circlip through service hole of #1 and #2 cylinders.

ST 499897200 PISTON CIRCLIP PLIERS

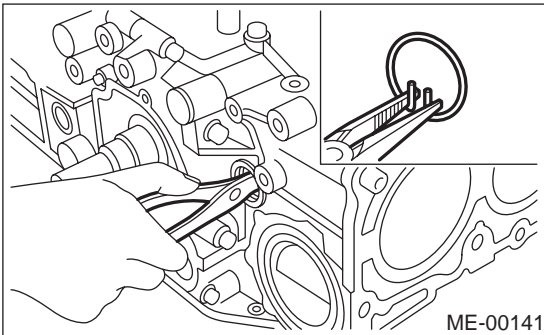

26) Draw out the piston pin from #1 and #2 pistons using ST.

ST 499097600 PISTON PIN REMOVER (MT vehicles)

ST 499097700 PISTON PIN REMOVER (AT vehicles)

NOTE:

Be careful not to confuse the original combination of piston, piston pin and cylinder.

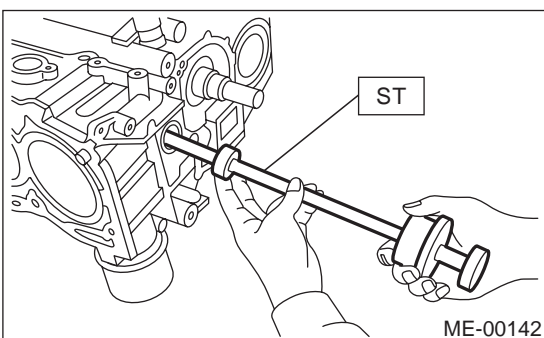

27) Similarly remove the piston pins from #3 and #4 pistons.

28) Remove the bolts which connect cylinder block on the side of #2 and #4 cylinders.

29) Back off the bolts which connect cylinder block on the side of #1 and #3 cylinders two or three turns.

30) Set up the cylinder block so that #1 and #3 cylinders are on the upper side, then remove the cylinder block connecting bolts.

31) Separate the cylinder blocks (LH) and (RH).

NOTE:

When separating the cylinder block, do not allow the connecting rod to fall and damage the cylinder block.

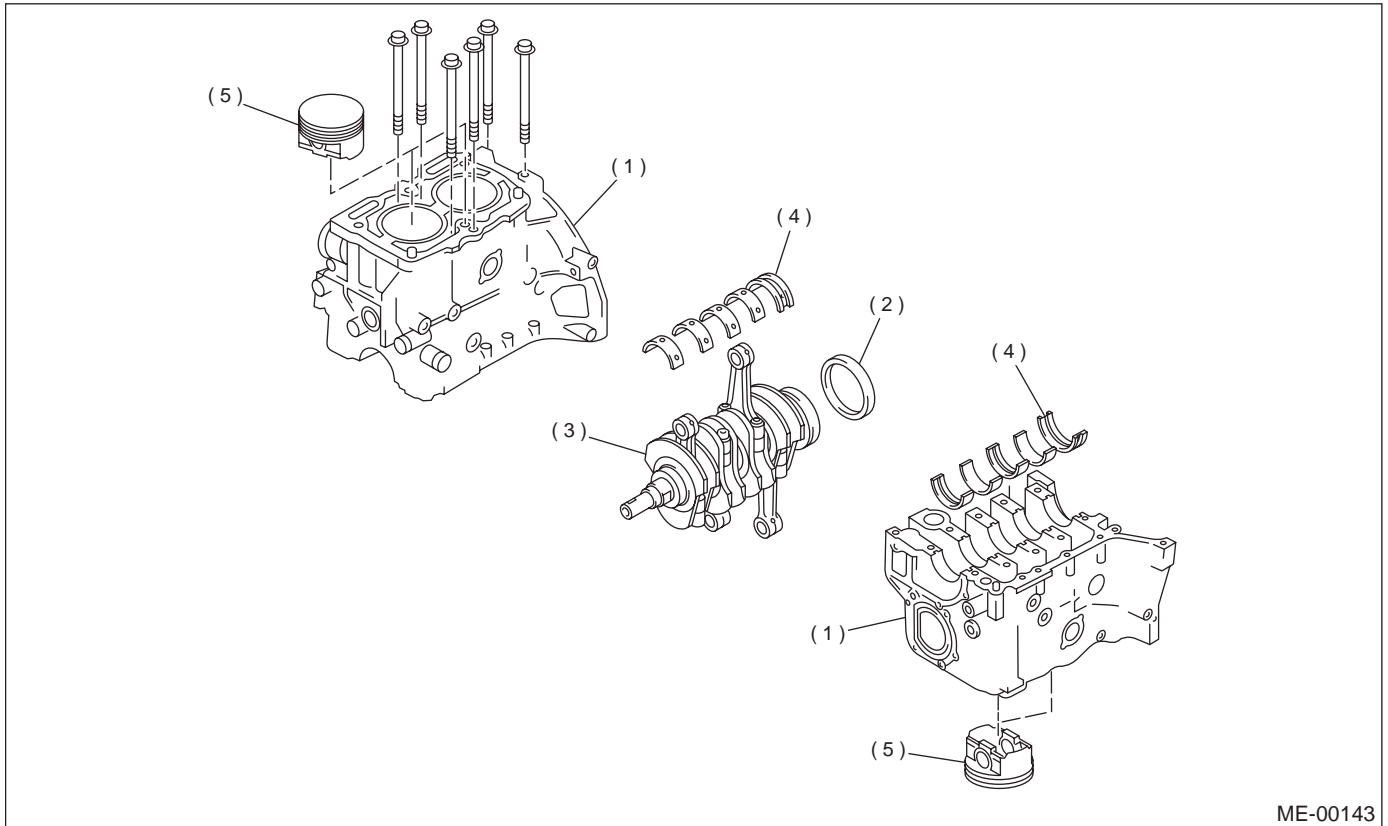

ME-00143

- | | | |
|--------------------|------------------------|------------|
| (1) Cylinder block | (3) Crankshaft | (5) Piston |
| (2) Rear oil seal | (4) Crankshaft bearing | |

- 32) Remove the rear oil seal.
- 33) Remove the crankshaft together with connecting rod.
- 34) Remove the crankshaft bearings from cylinder block using a hammer handle.

NOTE:

Do not confuse the combination of crankshaft bearings. Press the bearing at the end opposite to locking lip.

- 35) Draw out each piston from cylinder block using a wooden bar or hammer handle.

NOTE:

Do not confuse the combination of piston and cylinder.

CYLINDER BLOCK

MECHANICAL

B: INSTALLATION

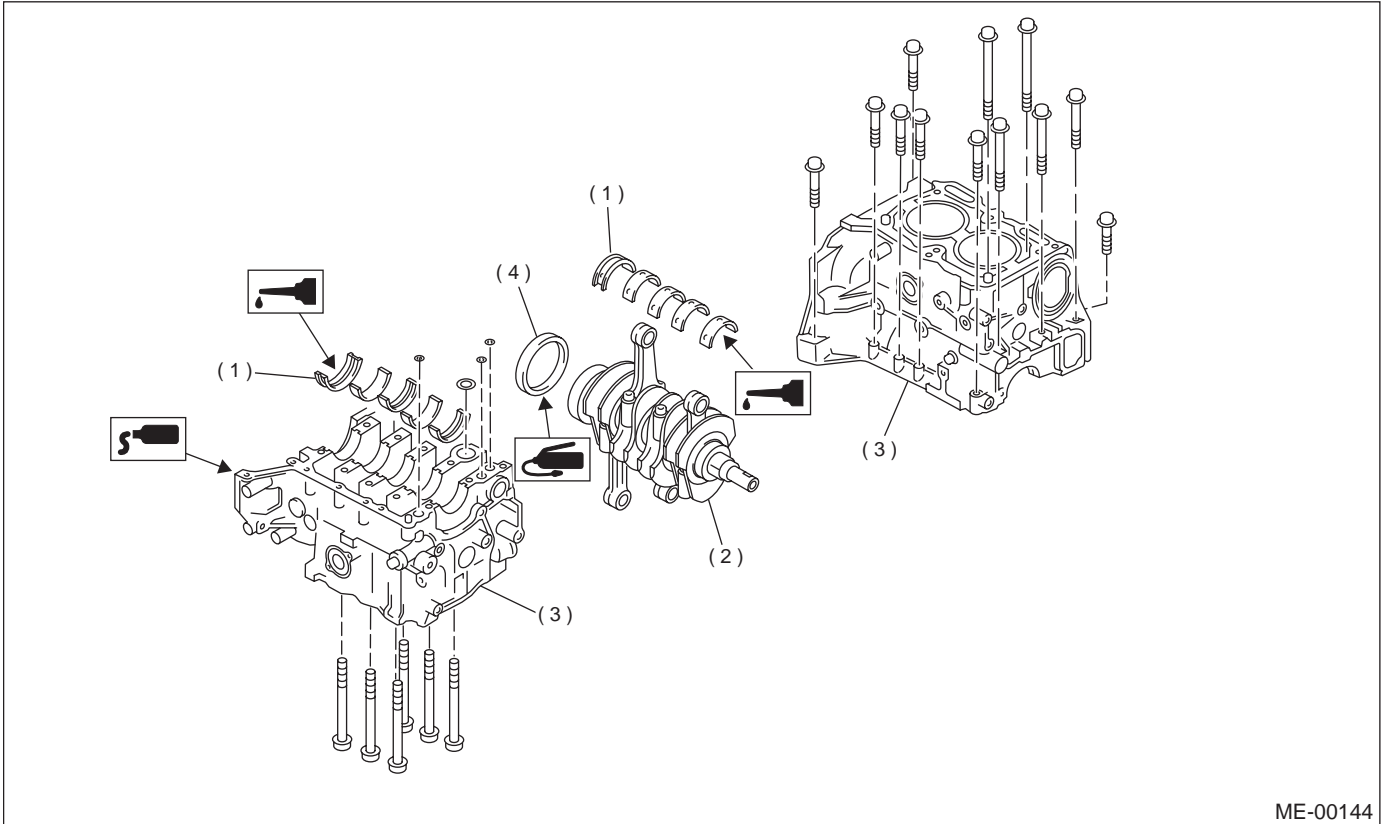

ME-00144

(1) Crankshaft bearing
(2) Crankshaft

(3) Cylinder block

(4) Rear oil seal

- 1) Remove oil in the mating surface of bearing and cylinder block before installation. Also apply a coat of engine oil to crankshaft pins.
- 2) Position the crankshaft on #2 and #4 cylinder block.
- 3) Apply fluid packing to the mating surface of #1 and #3 cylinder block, and position it on #2 and #4 cylinder block.

Fluid packing:

Part No. 004403007

THREE BOND 1215 or equivalent

NOTE:

Do not allow fluid packing to jut into O-ring grooves, oil passages, bearing grooves, etc.

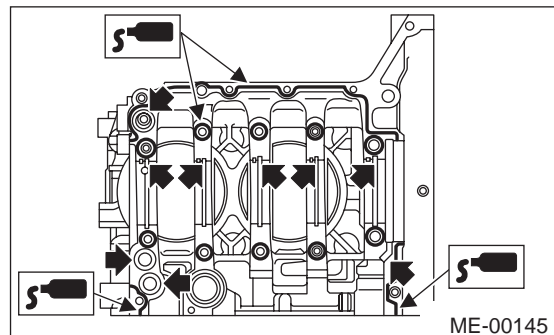

ME-00145

CYLINDER BLOCK

MECHANICAL

4) Tighten the 10 mm cylinder block connecting bolts in alphabetical sequence shown in the figure. (LH side)

Tightening torque:
15 N·m (1.5 kgf-m, 10.8 ft-lb)

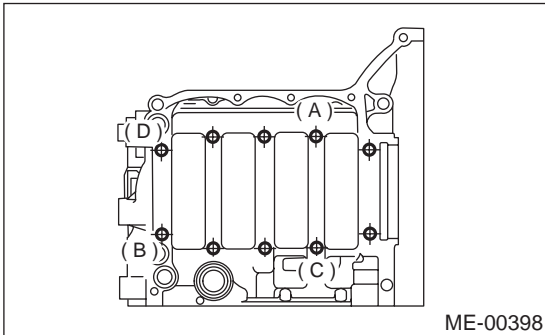

5) Tighten the 10 mm cylinder block connecting bolts in alphabetical sequence shown in the figure. (RH side)

Tightening torque:
15 N·m (1.5 kgf-m, 10.8 ft-lb)

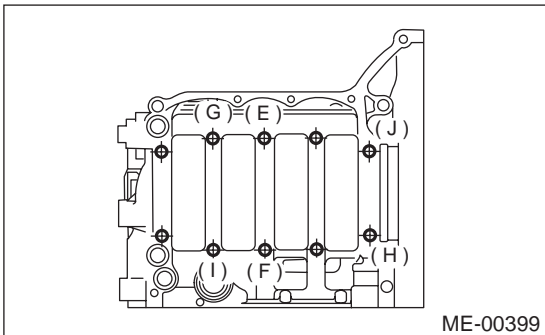

6) Further tighten the LH side bolts (A — D) to 90° in alphabetical sequence.

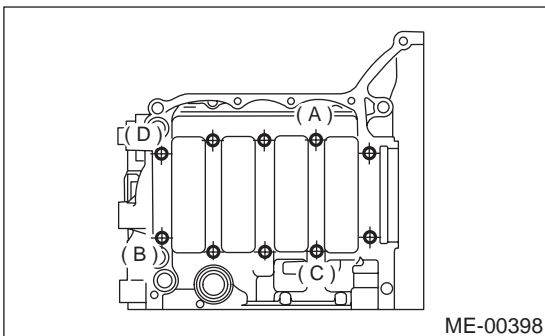

7) Further tighten the RH side bolts (E — J) to 90° in alphabetical sequence.

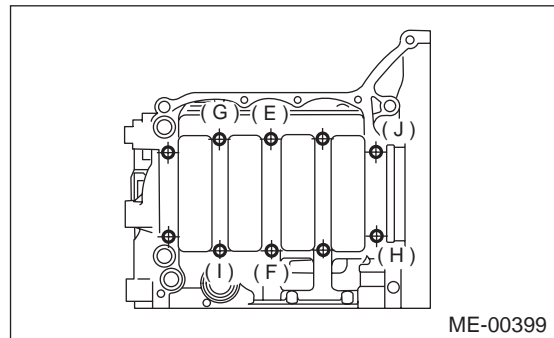

8) Tighten the 8 mm and 6 mm cylinder block connecting bolts in alphabetical sequence shown in the figure.

Tightening torque:
(A) — (G): 25 N·m (2.5 kgf-m, 18.1 ft-lb)
(H): 6.4 N·m (0.65 kgf-m, 4.7 ft-lb)

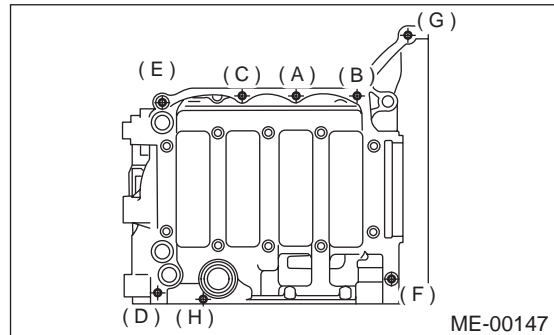

9) Install the rear oil seal using ST1 and ST2.
 ST1 499597100 OIL SEAL GUIDE
 ST2 499587200 OIL SEAL INSTALLER

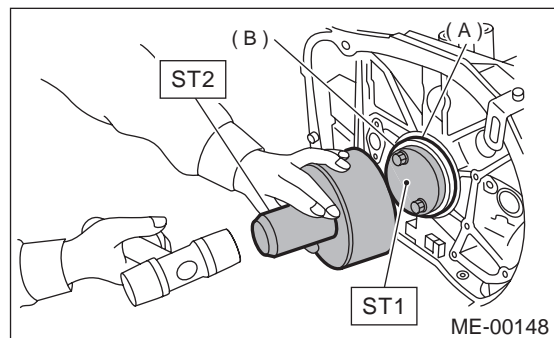

(A) Rear oil seal
 (B) Flywheel attaching bolt

10) Position the top ring gap at (A) or (B) in the figure.

CYLINDER BLOCK

MECHANICAL

11) Position the second ring gap at 180° on the reverse side for the top ring gap.

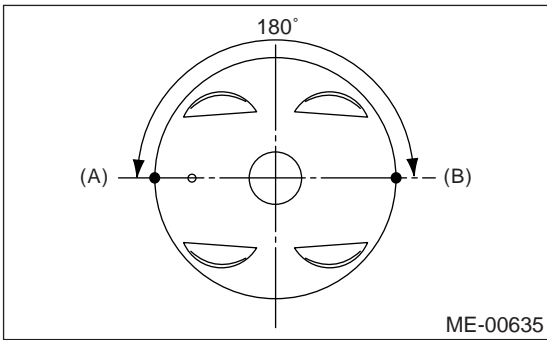

12) Position the expander rail gap at (C) in the figure.

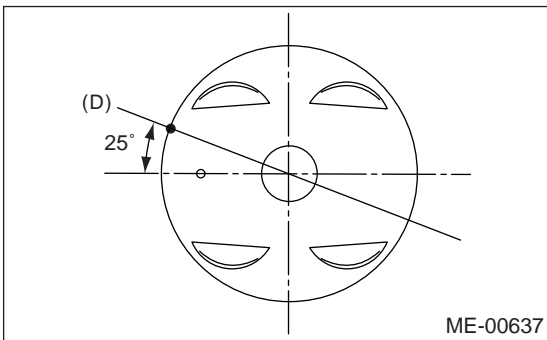
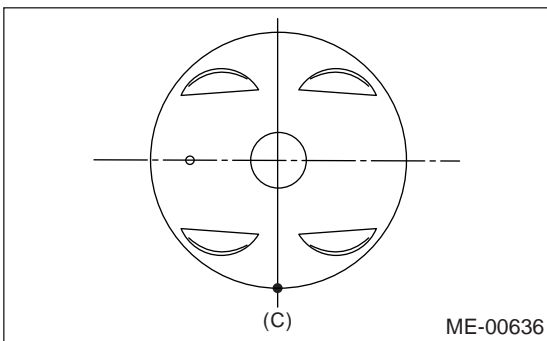

NOTE:
Align the lower rail spin stopper (F) with piston side surface hole (E).

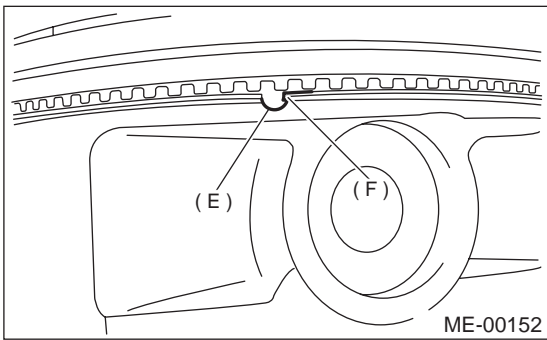

13) Position the upper rail gap at (G) in the figure.

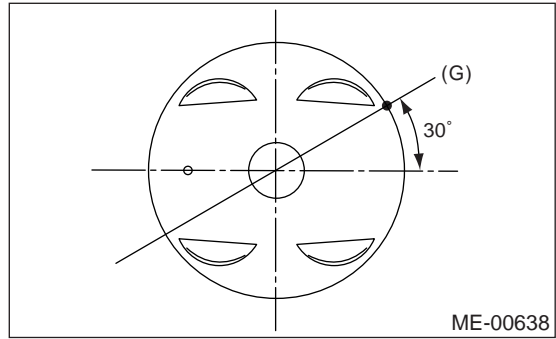

NOTE:

- Ensure ring gaps do not face the same direction.
- Ensure ring gaps are not within the piston skirt area.

14) Installing the circlip:

Install the circlips in piston holes located opposite of the service holes in cylinder block, when positioning all pistons in the corresponding cylinders.

NOTE:

Use new circlips.

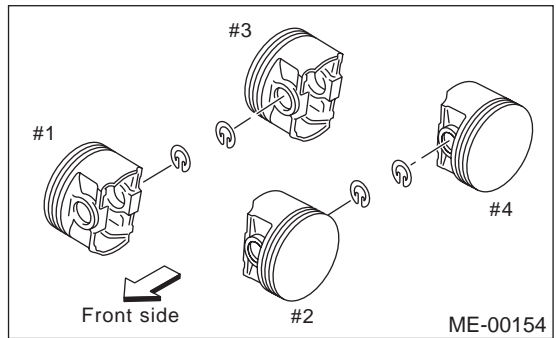

CYLINDER BLOCK

MECHANICAL

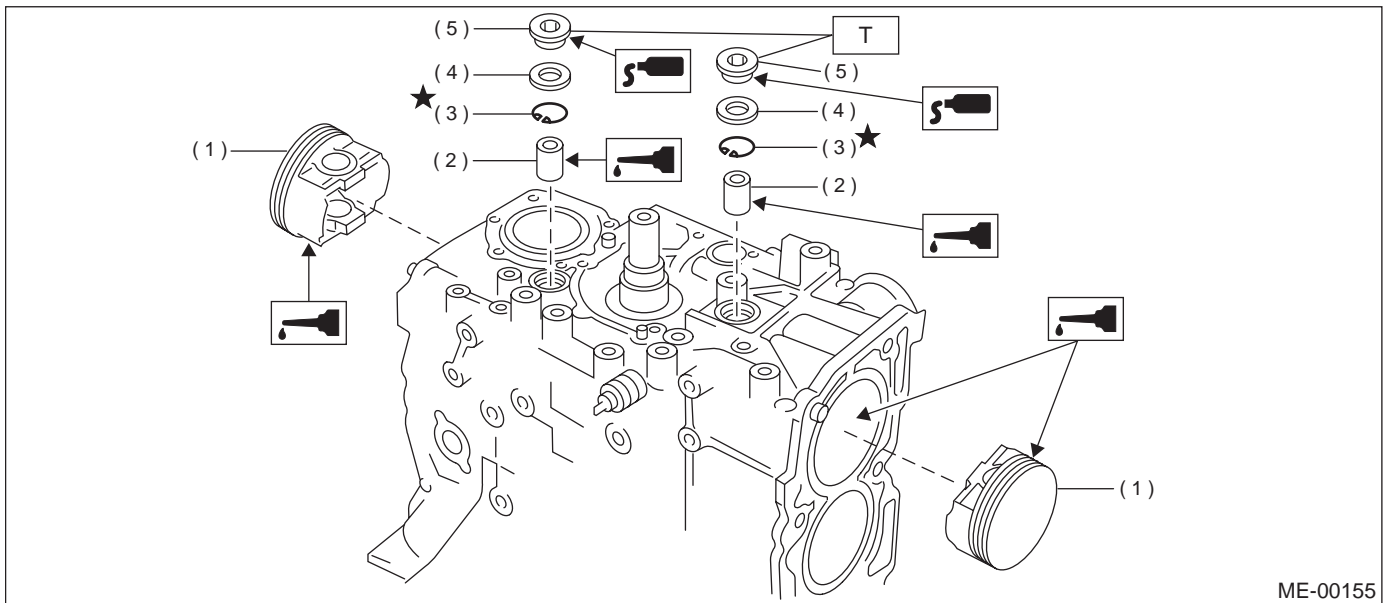

- (1) Piston
- (2) Piston pin
- (3) Circlip
- (4) Gasket
- (5) Service hole plug

Tightening torque : N·m (kgf·m, ft·lb)
T: 70 (7.1, 51.4)

15) Installing the piston:

- (1) Turn the cylinder block so that #1 and #2 cylinders face upward.
- (2) Using the ST1, turn the crankshaft so that #1 and #2 connecting rods are set at bottom dead center.

ST1 499987500 CRANKSHAFT SOCKET

- (3) Apply a coat of engine oil to the pistons and cylinders and insert pistons in their cylinders using ST2.

ST2 398744300 PISTON GUIDE

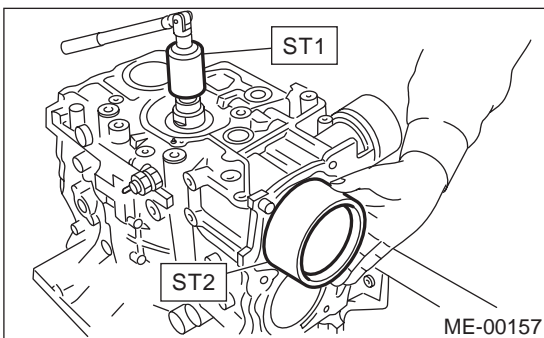

NOTE:

Piston front mark faces towards the front of the engine.

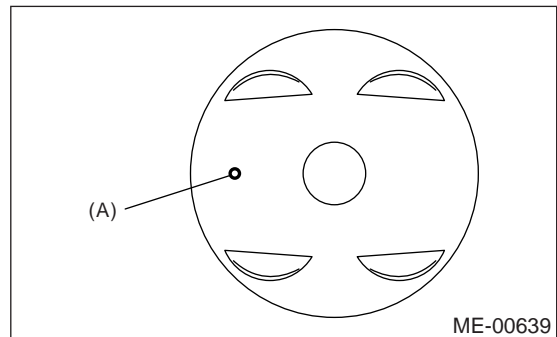

(A) Front mark

CYLINDER BLOCK

MECHANICAL

16) Installing piston pin:

- (1) Apply a coat of engine oil to ST3, and then insert the ST3 into service hole to align piston pin hole with connecting rod small end.

ST3 499017100 PISTON PIN GUIDE

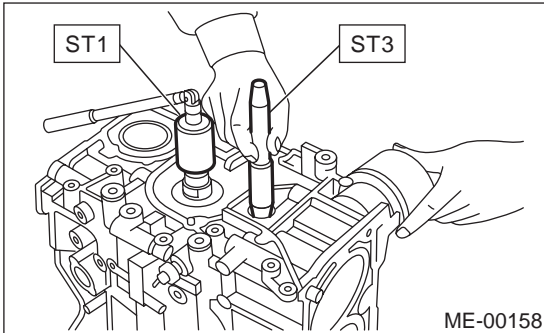

- (2) Apply a coat of engine oil to the piston pin and insert piston pin into piston and connecting rod through service hole.
- (3) Using the ST, install the circlip.

ST 499897200 PISTON CIRCLIP PLIERS

NOTE:

Use new circlips.

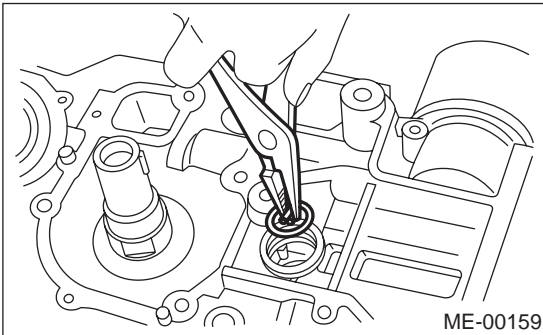

- (4) Apply fluid packing around the service hole plug.

Fluid packing:

Part No. 004403007

THREE BOND 1215 or equivalent

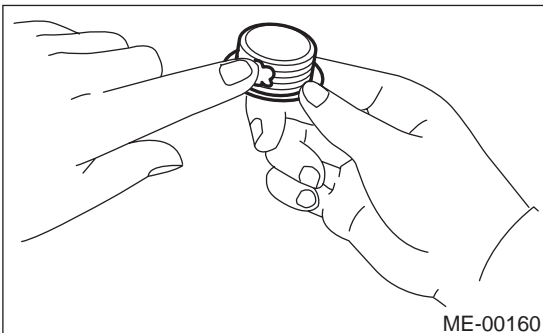

- (5) Install the service hole plug and gasket.

NOTE:

Use a new gasket.

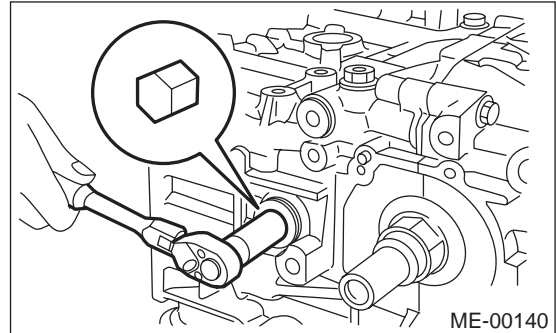

CYLINDER BLOCK

MECHANICAL

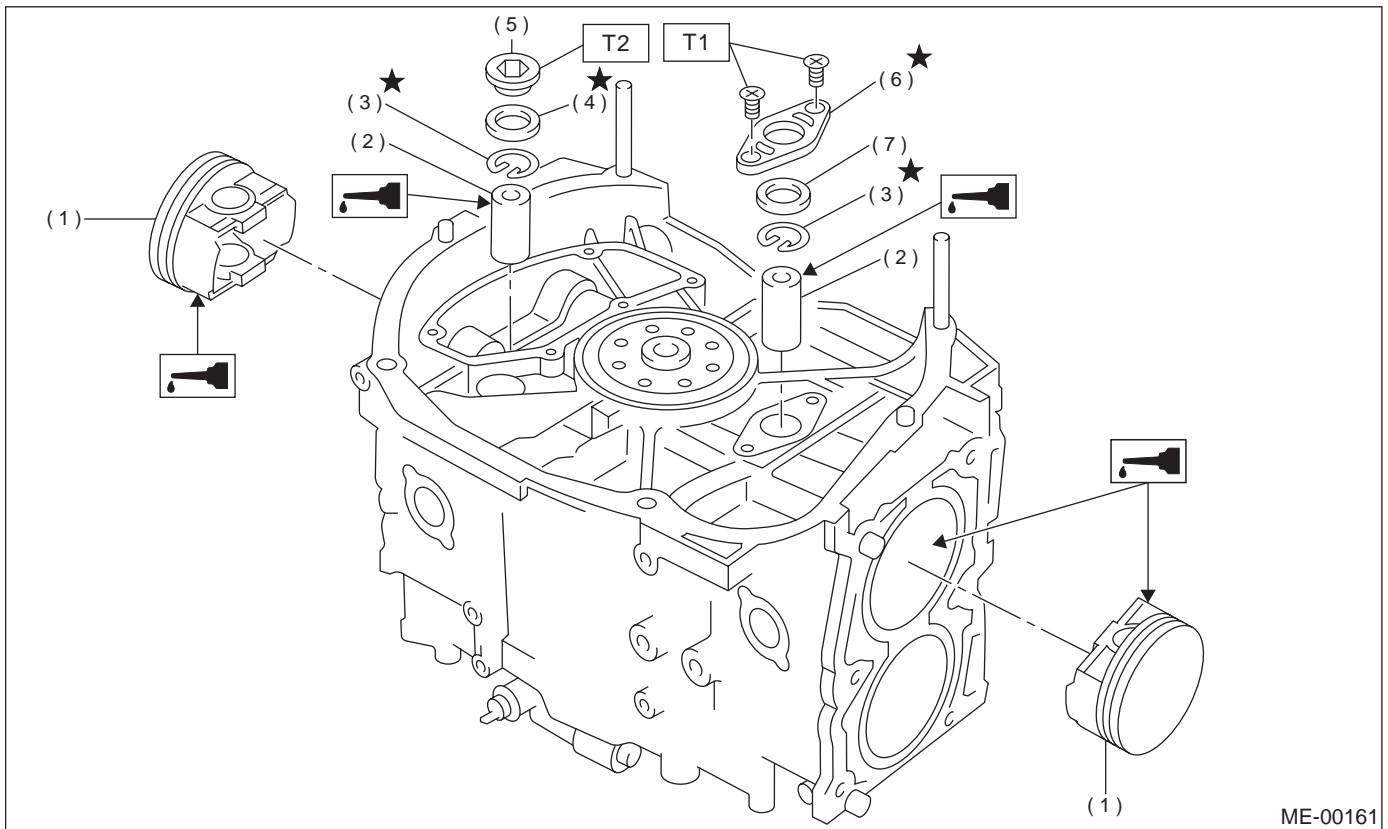

- | | |
|----------------|------------------------|
| (1) Piston | (5) Service hole plug |
| (2) Piston pin | (6) Service hole cover |
| (3) Circlip | (7) O-ring |
| (4) Gasket | |

Tightening torque : N-m (kgf-m, ft-lb)

T1: 6.4 (0.65, 4.7)

T2: 70 (7.1, 51.4)

(6) Turn the cylinder block so that #3 and #4 cylinders face upward. Using the same procedures as used for #1 and #2 cylinders, install the pistons and piston pins.

17) Install the water pipe.

18) Install the baffle plate.

Tightening torque:

6.4 N-m (0.65 kgf-m, 4.7 ft-lb)

19) Install the oil strainer and O-ring.

Tightening torque:

10 N-m (1.0 kgf-m, 7 ft-lb)

20) Install the oil strainer stay.

21) Apply fluid packing to the matching surfaces, and then install the oil pan.

Fluid packing:

Part No. 004403007

THREE BOND 1215 or equivalent

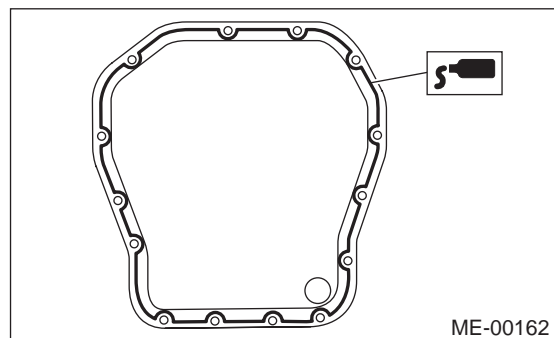

CYLINDER BLOCK

MECHANICAL

22) Apply fluid packing to the matching surfaces, and then install the oil separator cover.

Fluid packing:

Part No. 004403007

THREE BOND 1215 or equivalent

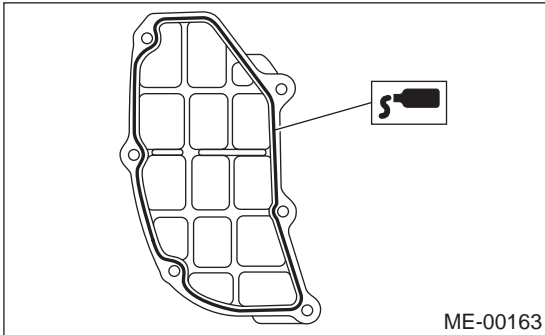

23) Install the drive plate. (AT vehicles)

To lock the crankshaft, use ST.

ST 498497100 CRANKSHAFT STOPPER

Tightening torque:

7.2 N·m (7.3 kgf-m, 52.8 ft-lb)

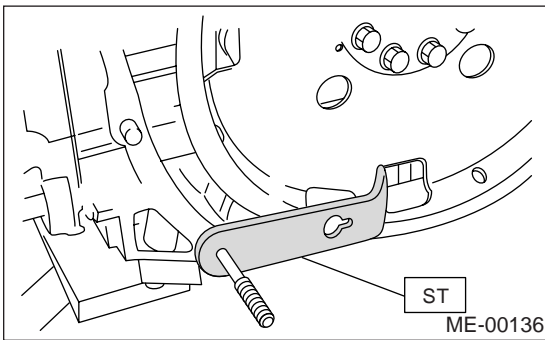

24) Install the flywheel. (MT vehicles) <Ref. to CL-20, INSTALLATION, Flywheel.>

25) Install the clutch disc and cover. (MT vehicles) <Ref. to CL-15, INSTALLATION, Clutch Disc and Cover.>

26) Installation of oil pump:

(1) Discard the front oil seal after removal. Replace with a new one using the ST.

ST 499587100 OIL SEAL INSTALLER

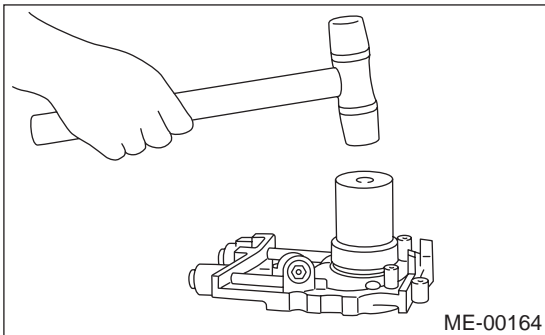

(2) Apply fluid packing to the matching surface of oil pump.

Fluid packing:

Part No. 004403007

THREE BOND 1215 or equivalent

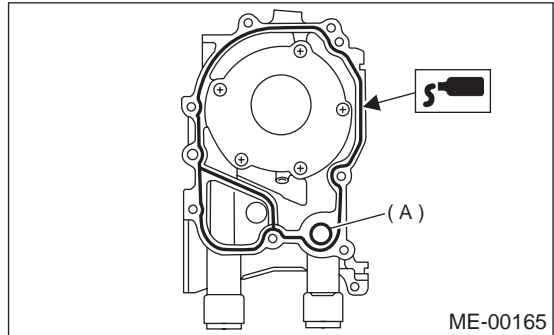

(A) O-ring

(3) Apply a coat of engine oil to the inside of the oil seal.

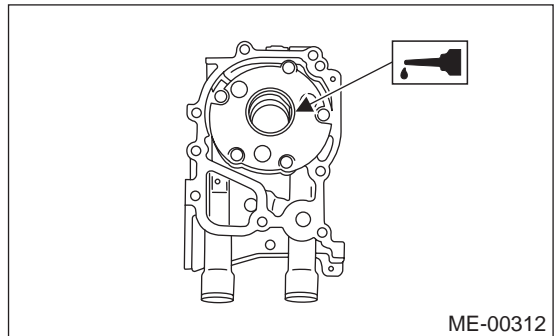

(4) Install the oil pump on cylinder block. Be careful not to damage the oil seal during installation.

Tightening torque:

6.4 N·m (0.65 kgf-m, 4.7 ft-lb)

NOTE:

- Do not forget to install the O-ring and seal when installing the oil pump.
- Align the flat surface of oil pump's inner rotor with crankshaft before installation.

27) Install the water pump and gasket.

Tightening torque:

First; 12 N·m (1.2 kgf-m, 8.7 ft-lb)

Second; 12 N·m (1.2 kgf-m, 8.7 ft-lb)

NOTE:

- Be sure to use a new gasket.
- When installing the water pump, tighten bolts in two stages in alphabetical sequence as shown in the figure.

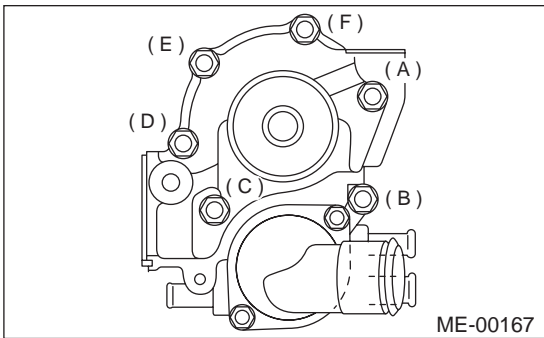

28) Install the water by-pass pipe for heater.

29) Install the oil cooler.

Tightening torque:

T1: 55 N·m (5.5 kgf-m, 40 ft-lb)

T2: 69 N·m (7.0 kgf-m, 50.6 ft-lb)

T3: 6.4 N·m (0.65 kgf-m, 4.7 ft-lb)

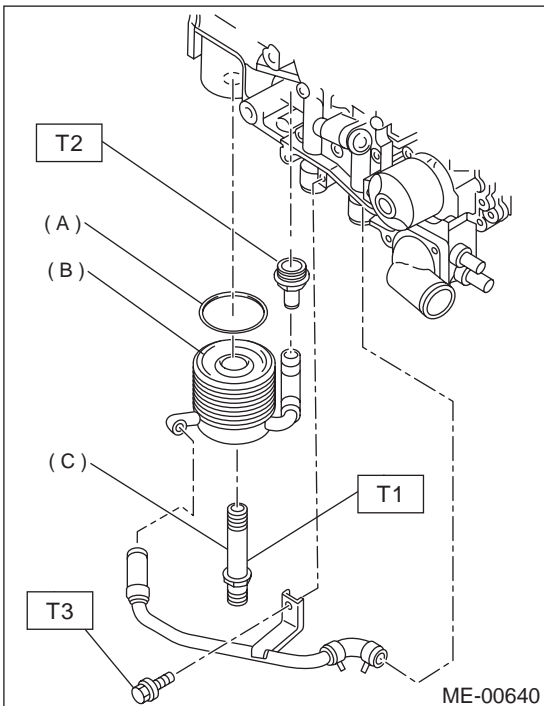

- (A) O-ring
- (B) Oil cooler
- (C) Oil cooler connector

30) Install the oil filter using ST.

ST 18332AA000 OIL FILTER WRENCH

31) Install the water by-pass pipe between oil cooler and water pump.

32) Install the water pipe.

NOTE:

Always use a new O-ring.

33) Install the cylinder head assembly.

<Ref. to ME(H4DOSTC)-62, INSTALLATION, CYLINDER HEAD ASSEMBLY.>

34) Install the oil level gauge guide and tighten the attaching bolt (left side only).

35) Install the rocker cover.

36) Install the crankshaft sprocket.

<Ref. to ME(H4DOSTC)-56, INSTALLATION, Crankshaft Sprocket.>

37) Install the camshaft sprocket.

<Ref. to ME(H4DOSTC)-55, INSTALLATION, Camshaft Sprocket.>

38) Install the timing belt assembly.

<Ref. to ME(H4DOSTC)-49, INSTALLATION, Timing Belt Assembly.>

39) Install the belt cover.

<Ref. to ME(H4DOSTC)-46, INSTALLATION, Belt Cover.>

40) Install the crankshaft pulley.

<Ref. to ME(H4DOSTC)-44, INSTALLATION, Crankshaft Pulley.>

41) Install the generator and A/C compressor brackets on cylinder head.

42) Install the V-belt.

<Ref. to ME(H4DOSTC)-42, INSTALLATION, V-belt.>

43) Install the intake manifold.

<Ref. to FU(H4DOSTC)-18, INSTALLATION, Intake Manifold.>

CYLINDER BLOCK

MECHANICAL

C: DISASSEMBLY

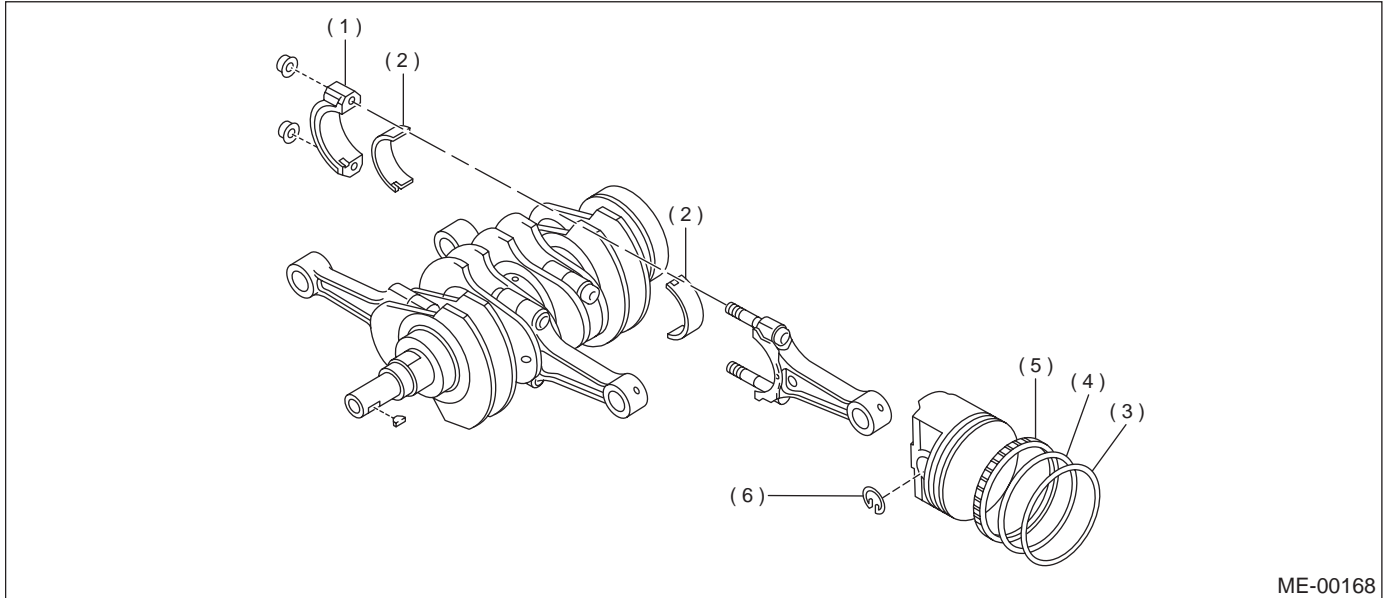

ME-00168

- (1) Connecting rod cap
- (2) Connecting rod bearing

- (3) Top ring
- (4) Second ring

- (5) Oil ring
- (6) Circlip

- 1) Remove the connecting rod cap.
- 2) Remove the connecting rod bearing.

NOTE:

Arrange the removed connecting rod, connecting rod cap and bearing in order to prevent confusion.

- 3) Remove the piston rings using the piston ring expander.
- 4) Remove the oil ring by hand.

NOTE:

Arrange the removed piston rings in proper order to prevent confusion.

- 5) Remove the circlip.

D: ASSEMBLY

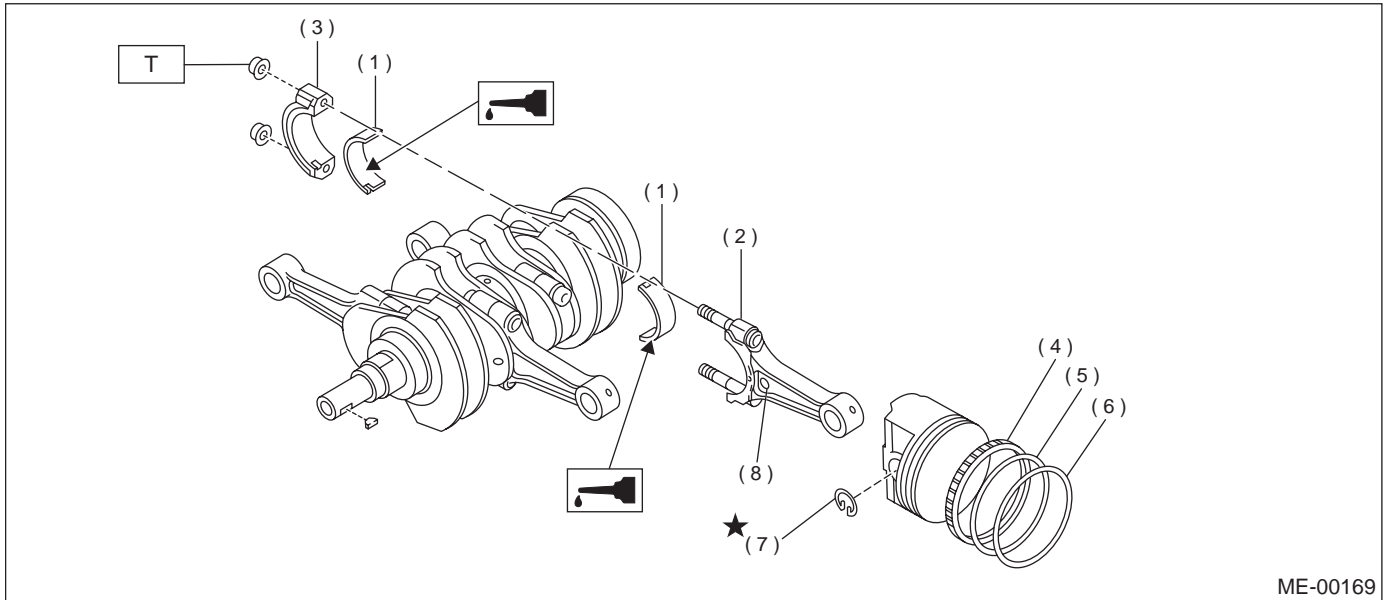

- | | |
|----------------------------|-----------------|
| (1) Connecting rod bearing | (5) Second ring |
| (2) Connecting rod | (6) Top ring |
| (3) Connecting rod cap | (7) Circlip |
| (4) Oil ring | (8) Side mark |

Tightening torque: N-m (kgf-m, ft-lb)

T: 45 (4.6, 33)

1) Apply oil to the surfaces of the connecting rod bearings. Install the connecting rod bearings on connecting rods and connecting rod caps.

2) Install the connecting rod on crankshaft.

NOTE:

Position each connecting rod with the side marked facing forward.

3) Install the connecting rod cap with connecting rod nut.

Ensure the arrow on connecting rod cap faces the front during installation.

NOTE:

- Each connecting rod has its own mating cap. Make sure that they are assembled correctly by checking their matching number.
- When tightening the connecting rod nuts, apply oil on the threads.

4) Install the oil ring spacer, upper rail and lower rail in this order by hand. Then install the second ring and top ring with a piston ring expander.

E: INSPECTION

1. CYLINDER BLOCK

1) Visually check for cracks and damage. Especially, inspect the important parts by means of red lead check.

2) Check the oil passages for clogging.

3) Inspect the crankcase surface that mates with cylinder head for warping by using a straight edge, and correct by grinding if necessary.

Warping limit:

0.05 mm (0.0020 in)

Grinding limit:

0.1 mm (0.004 in)

Standard height of cylinder block:

201.0 mm (7.91 in)

2. CYLINDER AND PISTON

1) The cylinder bore size is stamped on cylinder block's front upper surface.

NOTE:

Measurement should be performed at a temperature of 20°C (60°F).

NOTE:

Standard sized pistons are classified into two grades, "A" and "B". These grades should be used as a guide line in selecting a standard piston.

CYLINDER BLOCK

MECHANICAL

Standard diameter:

A: 92.005 — 92.015 mm (3.6222 — 3.6226 in)

B: 91.995 — 92.005 mm (3.6218 — 3.6222 in)

Taper:

Standard

0.015 mm (0.0006 in)

Limit

0.050 mm (0.0020 in)

Out-of-roundness:

Standard

0.010 mm (0.0004 in)

Limit

0.050 mm (0.0020 in)

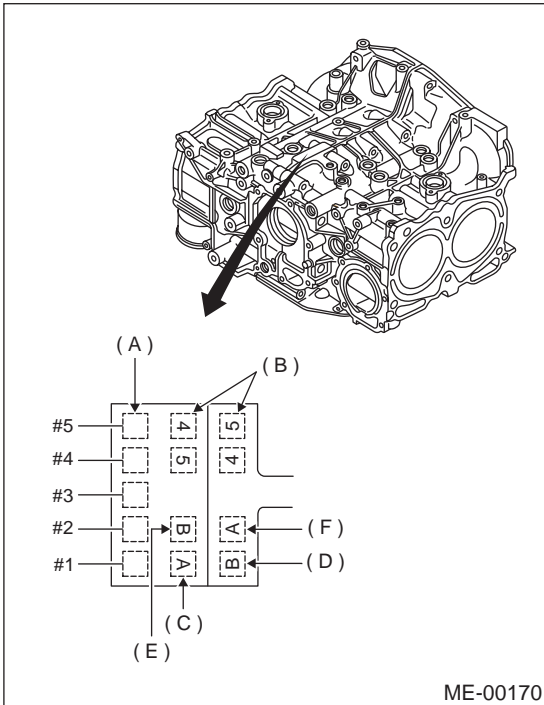

ME-00170

- (A) Main journal size mark
- (B) Cylinder block RH-LH combination mark
- (C) #1 cylinder bore size mark
- (D) #2 cylinder bore size mark
- (E) #3 cylinder bore size mark
- (F) #4 cylinder bore size mark

2) How to measure the inner diameter of each cylinder:

Measure the inner diameter of each cylinder in both the thrust and piston pin directions at the heights shown in the figure, using a cylinder bore gauge.

NOTE:

Measurement should be performed at a temperature of 20°C (68°F).

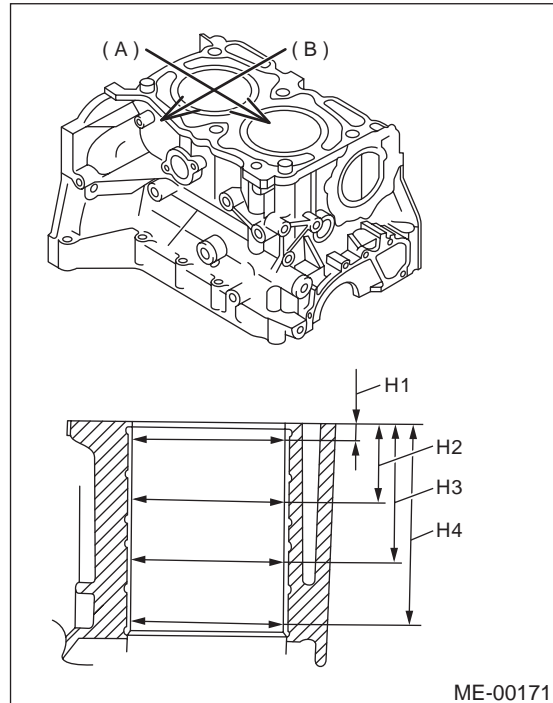

ME-00171

- (A) Piston pin direction
- (B) Thrust direction
- H1: 10 mm (0.39 in)
- H2: 45 mm (1.77 in)
- H3: 80 mm (3.15 in)
- H4: 115 mm (4.53 in)

3) When the piston is to be replaced due to general or cylinder wear, determine a suitable sized piston by measuring the piston clearance.

4) How to measure the outer diameter of each piston:

Measure the outer diameter of each piston at the height shown in the figure. (Thrust direction)

NOTE:

Measurement should be performed at a temperature of 20°C (68°F).

Piston grade point H:
38.7 mm (1.524 in)

Piston outer diameter:
Standard

A: 91.985 — 91.995 mm (3.6214 — 3.6218 in)

B: 91.975 — 91.985 mm (3.6211 — 3.6214 in)

0.25 mm (0.0098 in) oversize

92.225 — 92.235 mm (3.6309 — 3.6313 in)

0.50 mm (0.0197 in) oversize

92.475 — 92.485 mm (3.6407 — 3.6411 in)

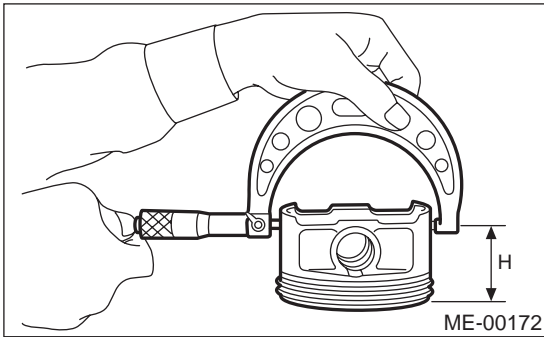

5) Calculate the clearance between cylinder and piston.

NOTE:

Measurement should be performed at a temperature of 20°C (68°F).

Cylinder to piston clearance at 20°C (68°F):

Standard

0.010 — 0.030 mm (0.0004 — 0.0012 in)

Limit

0.050 mm (0.0020 in)

6) Boring and honing:

(1) If the value of taper, out-of-roundness, or cylinder-to-piston clearance measured exceeds the specified limit or if there is any damage on the cylinder wall, rebore it to use an oversize piston.

NOTE:

When any of the cylinders needs reboring, all other cylinders must be bored at the same time, and use oversize pistons. Do not perform boring on one cylinder only, nor use an oversize piston for one cylinder only.

(2) If the cylinder inner diameter exceeds the limit after boring and honing, replace the crankcase.

NOTE:

Immediately after reboring, the cylinder diameter may differ from its real diameter due to temperature rise. Thus, pay attention to this when measuring the cylinder diameter.

Limit of cylinder enlarging (boring):
0.5 mm (0.020 in)

3. PISTON AND PISTON PIN

1) Check the pistons and piston pins for damage, cracks, and wear and the piston ring grooves for wear and damage. Replace if defective.

2) Measure the piston-to-cylinder clearance at each cylinder. <Ref. to ME(H4DOSTC)-83, CYLINDER AND PISTON, INSPECTION, Cylinder Block.> If any of the clearances is not within specification, replace the piston or bore the cylinder to use an oversize piston.

3) Make sure that the piston pin can be inserted into the piston pin hole with a thumb at 20°C (68°F). Replace if defective.

Standard clearance between piston pin and hole in piston:

Standard

0.004 — 0.008 mm (0.0002 — 0.0003 in)

Limit

0.020 mm (0.0008 in)

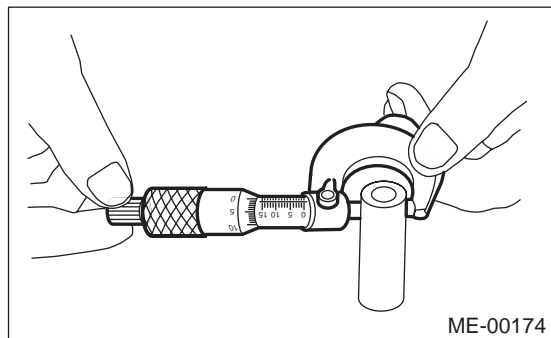
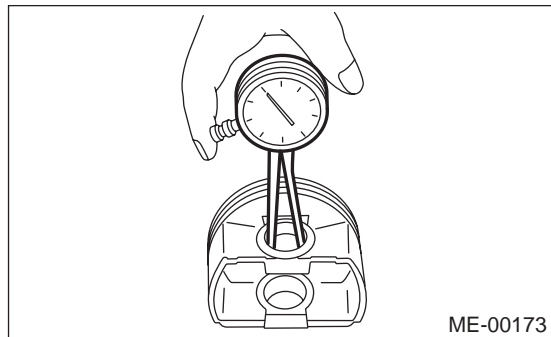

CYLINDER BLOCK

MECHANICAL

4) Check the circlip installation groove on piston for burr (A). If necessary, remove the burr from groove so that the piston pin can lightly move.

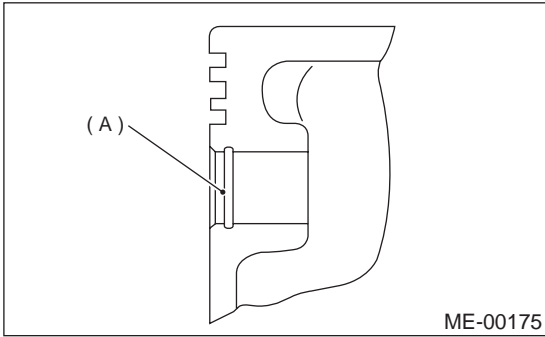

5) Check the piston pin circlip for distortion, cracks and wear.

4. PISTON RING

1) If the piston ring is broken, damaged, or worn, or if its tension is insufficient, or when the piston is replaced, replace the piston ring with a new one of the same size as the piston.

NOTE:

- Marks are shown on the end of top and second rings. When installing the rings to piston, face this mark upward.
- Oil ring consists of upper rail, expander and lower rail. When installing on piston, be careful of each rail's direction.

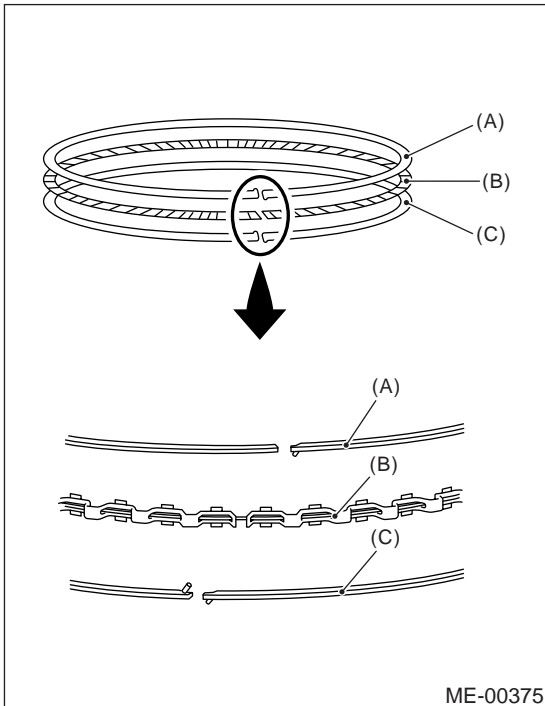

- (A) Upper rail
- (B) Expander
- (C) Lower rail

2) Clean up the piston ring groove and piston ring.
3) Squarely place the piston ring and oil ring in cylinder, and then measure the piston ring gap with a thickness gauge.

		Unit: mm (in)	
		Standard	Limit
Piston ring gap	Top ring	0.20 — 0.25 (0.0079 — 0.0098)	1.0 (0.039)
	Second ring	0.35 — 0.50 (0.0138 — 0.0197)	1.0 (0.039)
	Oil ring rail	0.20 — 0.50 (0.0079 — 0.0197)	1.5 (0.059)

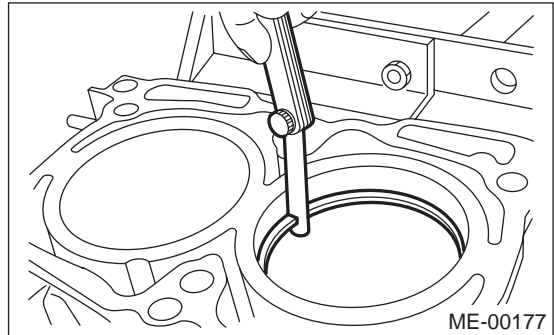

4) Measure the clearance between piston ring and piston ring groove with a thickness gauge.

NOTE:

Before measuring the clearance, clean the piston ring groove and piston ring.

		Unit: mm (in)	
		Standard	Limit
Clearance between piston ring and piston ring groove	Top ring	0.055 — 0.090 (0.0022 — 0.0035)	0.15 (0.0059)
	Second ring	0.030 — 0.070 (0.0012 — 0.0028)	0.15 (0.0059)

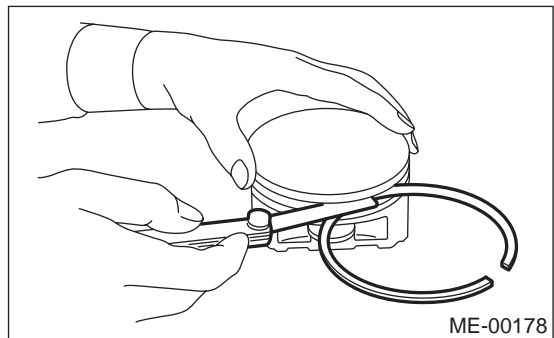

5. CONNECTING ROD

- 1) Replace the connecting rod, if the large or small end thrust surface is damaged.
- 2) Check for bend or twist using a connecting rod aligner. Replace the connecting rod if the bend or twist exceeds the limit.

Limit of bend or twist per 100 mm (3.94 in) in length:

0.10 mm (0.0039 in)

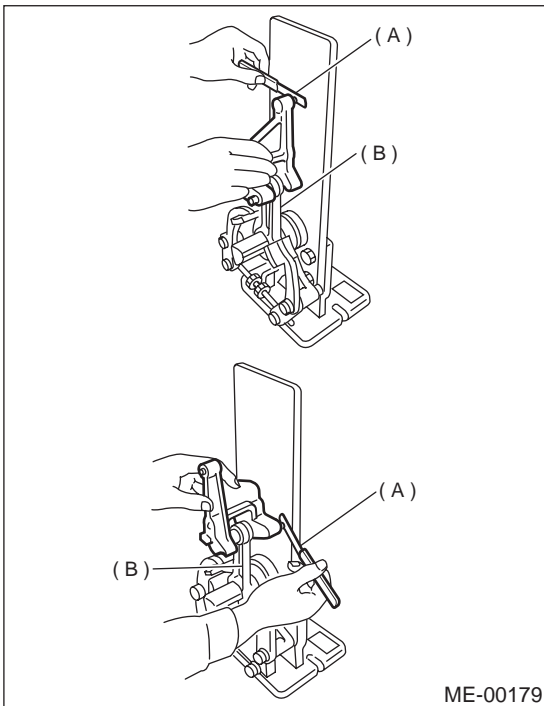

- (A) Thickness gauge
- (B) Connecting rod

- 3) Install the connecting rod fitted with bearing to crankshaft, and then measure the side clearance (thrust clearance). Replace the connecting rod if the side clearance exceeds the specified limit.

Connecting rod side clearance:

Standard

0.070 — 0.330 mm (0.0028 — 0.0130 in)

Limit

0.4 mm (0.016 in)

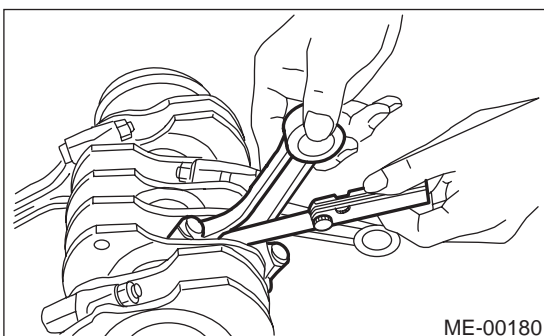

- 4) Inspect the connecting rod bearing for scar, peeling, seizure, melting, wear, etc.

- 5) Measure the oil clearance on individual connecting rod bearings by means of plastigauge. If any oil clearance is not within specification, replace the defective bearing with a new one of standard size or undersize as necessary. (See the table below.)

Connecting rod oil clearance:

Standard

0.020 — 0.046 mm (0.0008 — 0.0018 in)

Limit

0.05 mm (0.0020 in)

Unit: mm (in)		
Bearing	Bearing size (Thickness at center)	Outer diameter of crank pin
Standard	1.486 — 1.498 (0.0585 — 0.0590)	51.984 — 52.000 (2.0466 — 2.0472)
0.03 (0.0012) undersize	1.504 — 1.512 (0.0592 — 0.0595)	51.954 — 51.970 (2.0454 — 2.0461)
0.05 (0.0020) undersize	1.514 — 1.522 (0.0596 — 0.0599)	51.934 — 51.950 (2.0447 — 2.0453)
0.25 (0.0098) undersize	1.614 — 1.622 (0.0635 — 0.0639)	51.734 — 51.750 (2.0368 — 2.0374)

CYLINDER BLOCK

MECHANICAL

6) Inspect the bushing at connecting rod small end, and replace if worn or damaged. Also measure the piston pin clearance at connecting rod small end.

Clearance between piston pin and bushing:

Standard

0 — 0.022 mm (0 — 0.0009 in)

Limit

0.030 mm (0.0012 in)

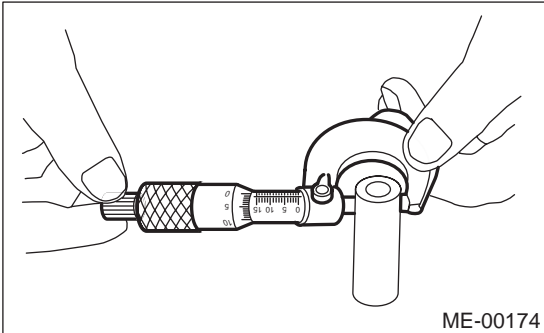
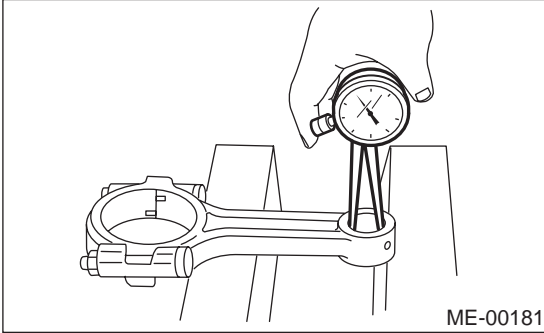

7) Replacement procedure is as follows:

- (1) Remove the bushing from connecting rod with ST and press.
- (2) Press the bushing with ST after applying oil on the periphery of bushing.

ST 499037100 CONNECTING ROD BUSHING REMOVER AND INSTALLER

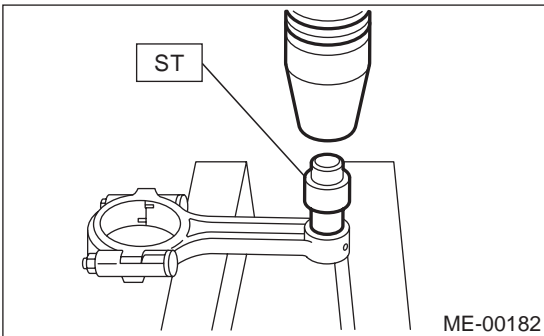

- (3) Make two 3 mm (0.12 in) holes in bushing. Ream the inside of bushing.
- (4) After the completion of reaming, clean the bushing to remove chips.

6. CRANKSHAFT AND CRANKSHAFT BEARING

- 1) Clean the crankshaft completely and check for cracks by means of red lead check etc., and replace if defective.
- 2) Measure the crankshaft bend, and correct or replace if it exceeds the limit.

NOTE:

If a suitable V-block is not available, install the #1 and #5 crankshaft bearing on cylinder block, position the crankshaft on these bearings and measure the crankshaft bend using a dial gauge.

Crankshaft bend limit:

0.035 mm (0.0014 in)

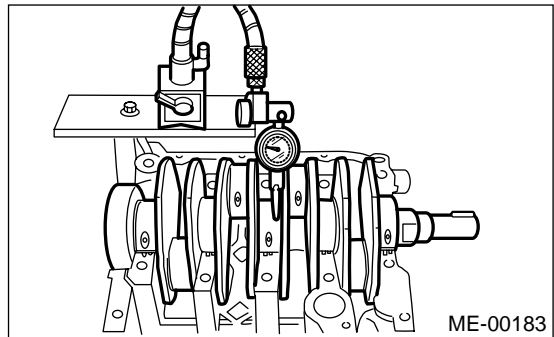

- 3) Inspect the crank journal and crank pin for wear. If they are not within the specifications, replace the bearing with a suitable (undersize) one, and then replace or recondition the crankshaft as necessary. When grinding the crank journal or crank pin, finish them to specified dimensions according to the undersize bearing to be used.

Crank pin and crank journal:

Out-of-roundness

0.020 mm (0.0008 in) or less

Taper limit

0.07 mm (0.0028 in)

Grinding limit

0.250 mm (0.0098 in)

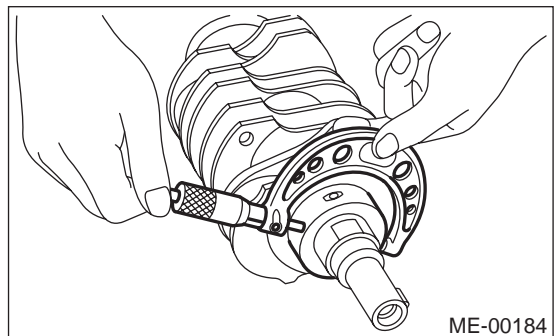

CYLINDER BLOCK

MECHANICAL

		Crank journal diameter		Unit: mm (in)
		#1, #3, #5	#2, #4	Crank pin diameter
Standard	Journal O.D.	59.992 — 60.008 (2.3619 — 2.3625)	59.992 — 60.008 (2.3619 — 2.3625)	51.984 — 52.000 (2.0466 — 2.0472)
	Bearing size (Thickness at center)	1.998 — 2.011 (0.0787 — 0.0792)	2.000 — 2.013 (0.0787 — 0.0793)	1.486 — 1.498 (0.0585 — 0.0590)
0.03 (0.0012) undersize	Journal O.D.	59.962 — 59.978 (2.3607 — 2.3613)	59.962 — 59.978 (2.3607 — 2.3613)	51.954 — 51.970 (2.0454 — 2.0461)
	Bearing size (Thickness at center)	2.017 — 2.020 (0.0794 — 0.0795)	2.019 — 2.022 (0.0795 — 0.0796)	1.504 — 1.512 (0.0592 — 0.0595)
0.05 (0.0020) undersize	Journal O.D.	59.942 — 59.958 (2.3599 — 2.3605)	59.942 — 59.958 (2.3599 — 2.3605)	51.934 — 51.950 (2.0447 — 2.0453)
	Bearing size (Thickness at center)	2.027 — 2.030 (0.0798 — 0.0799)	2.029 — 2.032 (0.0799 — 0.0800)	1.514 — 1.522 (0.0596 — 0.0599)
0.25 (0.0098) undersize	Journal O.D.	59.742 — 59.758 (2.3520 — 2.3527)	59.742 — 59.758 (2.3520 — 2.3527)	51.734 — 51.750 (2.0368 — 2.0374)
	Bearing size (Thickness at center)	2.127 — 2.130 (0.0837 — 0.0839)	2.129 — 2.132 (0.0838 — 0.0839)	1.614 — 1.622 (0.0635 — 0.0639)

O.D.: Outer Diameter

4) Measure the thrust clearance of crankshaft at center bearing. If the clearance exceeds the limit, replace the bearing.

Crankshaft thrust clearance:

Standard

0.030 — 0.115 mm (0.0012 — 0.0045 in)

Limit

0.25 mm (0.0098 in)

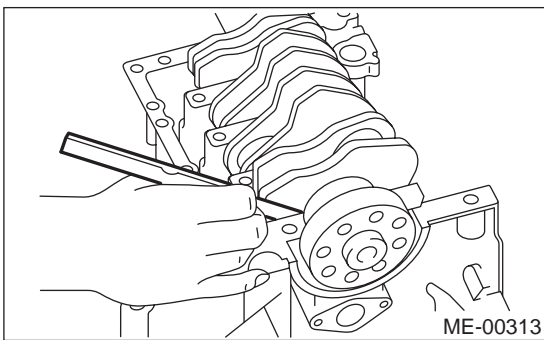

			Unit: mm (in)
			Crankshaft oil clearance
#1	STD	0.003 — 0.030 (0.0001 — 0.0012)	
	Limit	0.040 (0.0016)	
#2	STD	0.012 — 0.033 (0.0005 — 0.0013)	
	Limit	0.045 (0.0018)	
#3	STD	0.003 — 0.030 (0.0001 — 0.0012)	
	Limit	0.040 (0.0016)	
#4	STD	0.012 — 0.033 (0.0005 — 0.0013)	
	Limit	0.045 (0.0018)	
#5	STD	0.010 — 0.031 (0.0004 — 0.0012)	
	Limit	0.040 (0.0016)	

5) Inspect individual crankshaft bearings for signs of flaking, seizure, melting, and wear.

6) Measure the oil clearance on each crankshaft bearing by means of plastigauge. If the measurement is not within the specification, replace the defective bearing with an undersize one, and replace or recondition the crankshaft as necessary.

ENGINE TROUBLE IN GENERAL

MECHANICAL

21.Engine Trouble in General

A: INSPECTION

NOTE:

“RANK” shown in the chart refers to the possibility of reason for the trouble in order (“Very often” to “Rarely”)

A — Very often

B — Sometimes

C — Rarely

TROUBLE	PROBLEM PARTS, ETC.	POSSIBLE CAUSE	RANK
1. Engine will not start.			
1) Starter does not turn.	• Starter	• Defective battery-to-starter harness	B
		• Defective starter switch	C
		• Defective inhibitor switch or neutral switch	C
		• Defective starter	B
	• Battery	• Poor terminal connection	A
		• Run-down battery	A
		• Defective charging system	B
	• Friction	• Seizure of crankshaft and connecting rod bearing	C
		• Seized camshaft	C
		• Seized or stuck piston and cylinder	C
2) Initial combustion does not occur.	• Starter	• Defective starter	C
	• Engine control system <Ref. to EN(H4DOSTC)-2, Basic Diagnostic Procedure.>		A
	• Fuel line	• Defective fuel pump and relay	A
		• Lack of or insufficient fuel	B
	• Belt	• Defective	B
		• Defective timing	B
	• Compression	• Incorrect valve clearance	C
		• Loosened spark plugs or defective gasket	C
		• Loosened cylinder head bolts or defective gasket	C
		• Improper valve seating	C
		• Defective valve stem	C
		• Worn or broken valve spring	B
		• Worn or stuck piston rings, cylinder and piston	C
		• Incorrect valve timing	B
	• Improper engine oil (low viscosity)	B	
	3) Initial combustion occur.	• Engine control system <Ref. to EN(H4DOSTC)-2, Basic Diagnostic Procedure.>	
• Intake system		• Defective intake manifold gasket	B
		• Defective throttle body gasket	B
• Fuel line		• Defective fuel pump and relay	C
		• Clogged fuel line	C
		• Lack of or insufficient fuel	B
• Belt		• Defective	B
		• Defective timing	B
• Compression		• Incorrect valve clearance	C
		• Loosened spark plugs or defective gasket	C
		• Loosened cylinder head bolts or defective gasket	C
		• Improper valve seating	C
		• Defective valve stem	C
		• Worn or broken valve spring	B
		• Worn or stuck piston rings, cylinder and piston	C
		• Incorrect valve timing	B
• Improper engine oil (low viscosity)	B		

ENGINE TROUBLE IN GENERAL

MECHANICAL

TROUBLE	PROBLEM PARTS, ETC.	POSSIBLE CAUSE	RANK
4) Engine stalls after initial combustion.	• Engine control system <Ref. to EN(H4DOSTC)-2, Basic Diagnostic Procedure.>		A
	• Intake system	• Loosened or cracked intake duct	B
		• Loosened or cracked PCV hose	C
		• Loosened or cracked vacuum hose	C
		• Defective intake manifold gasket	B
		• Defective throttle body gasket	B
		• Dirty air cleaner element	C
	• Fuel line	• Clogged fuel line	C
		• Lack of or insufficient fuel	B
	• Belt	• Defective	B
		• Defective timing	B
	• Compression	• Incorrect valve clearance	C
		• Loosened spark plugs or defective gasket	C
		• Loosened cylinder head bolts or defective gasket	C
		• Improper valve seating	C
		• Defective valve stem	C
		• Worn or broken valve spring	B
• Worn or stuck piston rings, cylinder and piston		C	
• Incorrect valve timing		B	
• Improper engine oil (low viscosity)		B	
2. Rough idle and engine stall	• Engine control system <Ref. to EN(H4DOSTC)-2, Basic Diagnostic Procedure.>		A
	• Intake system	• Loosened or cracked intake duct	A
		• Loosened or cracked PCV hose	A
		• Loosened or cracked vacuum hose	A
		• Defective intake manifold gasket	B
		• Defective throttle body gasket	B
		• Defective PCV valve	C
		• Loosened oil filler cap	B
		• Dirty air cleaner element	C
	• Fuel line	• Defective fuel pump and relay	C
		• Clogged fuel line	C
		• Lack of or insufficient fuel	B
	• Belt	• Defective timing	C
	• Compression	• Incorrect valve clearance	B
		• Loosened spark plugs or defective gasket	B
		• Loosened cylinder head bolts or defective gasket	B
		• Improper valve seating	B
		• Defective valve stem	C
		• Worn or broken valve spring	B
		• Worn or stuck piston rings, cylinder and piston	B
		• Incorrect valve timing	A
		• Improper engine oil (low viscosity)	B
	• Lubrication system	• Incorrect oil pressure	B
		• Defective rocker cover gasket	C
	• Cooling system	• Overheating	C
	• Others	• Malfunction of evaporative emission control system	A
		• Stuck or damaged throttle valve	B
		• Accelerator cable out of adjustment	C

ENGINE TROUBLE IN GENERAL

MECHANICAL

TROUBLE	PROBLEM PARTS, ETC.	POSSIBLE CAUSE	RANK
3. Low output, hesitation and poor acceleration	• Engine control system <Ref. to EN(H4DOSTC)-2, Basic Diagnostic Procedure.>		A
	• Intake system	• Loosened or cracked intake duct	A
		• Loosened or cracked PCV hose	A
		• Loosened or cracked vacuum hose	B
		• Defective intake manifold gasket	B
		• Defective throttle body gasket	B
		• Defective PCV valve	B
		• Loosened oil filler cap	B
		• Dirty air cleaner element	A
	• Fuel line	• Defective fuel pump and relay	B
		• Clogged fuel line	B
		• Lack of or insufficient fuel	C
	• Belt	• Defective timing	B
	• Compression	• Incorrect valve clearance	B
		• Loosened spark plugs or defective gasket	B
		• Loosened cylinder head bolts or defective gasket	B
		• Improper valve seating	B
		• Defective valve stem	C
		• Worn or broken valve spring	B
		• Worn or stuck piston rings, cylinder and piston	C
• Incorrect valve timing		A	
• Improper engine oil (low viscosity)	B		
• Lubrication system	• Incorrect oil pressure	B	
• Cooling system	• Overheating	C	
	• Over cooling	C	
• Others	• Malfunction of evaporative emission control system	A	
4. Surging	• Engine control system <Ref. to EN(H4DOSTC)-2, Basic Diagnostic Procedure.>		A
	• Intake system	• Loosened or cracked intake duct	A
		• Loosened or cracked PCV hose	A
		• Loosened or cracked vacuum hose	A
		• Defective intake manifold gasket	B
		• Defective throttle body gasket	B
		• Defective PCV valve	B
		• Loosened oil filler cap	B
		• Dirty air cleaner element	B
	• Fuel line	• Defective fuel pump and relay	B
		• Clogged fuel line	B
		• Lack of or insufficient fuel	C
	• Belt	• Defective timing	B
	• Compression	• Incorrect valve clearance	B
		• Loosened spark plugs or defective gasket	C
		• Loosened cylinder head bolts or defective gasket	C
		• Improper valve seating	C
		• Defective valve stem	C
		• Worn or broken valve spring	C
		• Worn or stuck piston rings, cylinder and piston	C
• Incorrect valve timing		A	
• Improper engine oil (low viscosity)	B		
• Cooling system	• Overheating	B	
• Others	• Malfunction of evaporative emission control system	C	

ENGINE TROUBLE IN GENERAL

MECHANICAL

TROUBLE	PROBLEM PARTS, ETC.	POSSIBLE CAUSE	RANK
5. Engine does not return to idle.	• Engine control system <Ref. to EN(H4DOSTC)-2, Basic Diagnostic Procedure.>		A
	• Intake system	• Loosened or cracked vacuum hose	A
	• Others	• Stuck or damaged throttle valve	A
		• Accelerator cable out of adjustment	B
6. Dieseling (Run-on)	• Engine control system <Ref. to EN(H4DOSTC)-2, Basic Diagnostic Procedure.>		A
	• Cooling system	• Overheating	B
	• Others	• Malfunction of evaporative emission control system	B
7. After burning in exhaust system	• Engine control system <Ref. to EN(H4DOSTC)-2, Basic Diagnostic Procedure.>		A
	• Intake system	• Loosened or cracked intake duct	C
		• Loosened or cracked PCV hose	C
		• Loosened or cracked vacuum hose	B
		• Defective PCV valve	B
		• Loosened oil filler cap	C
	• Belt	• Defective timing	B
	• Compression	• Incorrect valve clearance	B
		• Loosened spark plugs or defective gasket	C
		• Loosened cylinder head bolts or defective gasket	C
		• Improper valve seating	B
		• Defective valve stem	C
		• Worn or broken valve spring	C
		• Worn or stuck piston rings, cylinder and piston	C
	• Incorrect valve timing	A	
	• Lubrication system	• Incorrect oil pressure	C
• Cooling system	• Over cooling	C	
• Others	• Malfunction of evaporative emission control system	C	
8. Knocking	• Engine control system <Ref. to EN(H4DOSTC)-2, Basic Diagnostic Procedure.>		A
	• Intake system	• Loosened oil filler cap	B
	• Belt	• Defective timing	B
	• Compression	• Incorrect valve clearance	C
		• Incorrect valve timing	B
	• Cooling system	• Overheating	A
9. Excessive engine oil consumption	• Intake system	• Loosened or cracked PCV hose	A
		• Defective PCV valve	B
		• Loosened oil filler cap	C
	• Compression	• Defective valve stem	A
		• Worn or stuck piston rings, cylinder and piston	A
	• Lubrication system	• Loosened oil pump attaching bolts and defective gasket	B
		• Defective oil filler o-ring	B
		• Defective crankshaft oil seal	B
		• Defective rocker cover gasket	B
		• Loosened oil drain plug or defective gasket	B
	• Loosened oil pan fitting bolts or defective oil pan	B	

ENGINE TROUBLE IN GENERAL

MECHANICAL

TROUBLE	PROBLEM PARTS, ETC.	POSSIBLE CAUSE	RANK	
10. Excessive fuel consumption	• Engine control system <Ref. to EN(H4DOSTC)-2, Basic Diagnostic Procedure.>		A	
	• Intake system	• Dirty air cleaner element	A	
	• Belt	• Defective timing	B	
	• Compression	• Incorrect valve clearance		B
		• Loosened spark plugs or defective gasket		C
		• Loosened cylinder head bolts or defective gasket		C
		• Improper valve seating		B
		• Defective valve stem		C
		• Worn or broken valve spring		C
		• Worn or stuck piston rings, cylinder and piston		B
		• Incorrect valve timing		B
	• Lubrication system	• Incorrect oil pressure	C	
	• Cooling system	• Over cooling	C	
• Others	• Accelerator cable out of adjustment	B		

22.Engine Noise

A: INSPECTION

Type of sound	Condition	Possible cause
Regular clicking sound	Sound increases as engine speed increases.	<ul style="list-style-type: none"> Valve mechanism is defective. Incorrect valve clearance Worn valve rocker Worn camshaft Broken valve spring
Heavy and dull clank	Oil pressure is low.	<ul style="list-style-type: none"> Worn crankshaft main bearing Worn connecting rod bearing (big end)
	Oil pressure is normal.	<ul style="list-style-type: none"> Loose flywheel mounting bolts Damaged engine mounting
High-pitched clank (Spark knock)	Sound is noticeable when accelerating with an overload.	<ul style="list-style-type: none"> Ignition timing advanced Accumulation of carbon inside combustion chamber Wrong spark plug Improper gasoline
Clank when engine speed is medium (1,000 to 2,000 rpm).	Sound is reduced when fuel injector connector of noisy cylinder is disconnected. (NOTE*)	<ul style="list-style-type: none"> Worn crankshaft main bearing Worn bearing at crankshaft end of connecting rod
Knocking sound when engine is operating under idling speed and engine is warm	Sound is reduced when fuel injector connector of noisy cylinder is disconnected. (NOTE*)	<ul style="list-style-type: none"> Worn cylinder liner and piston ring Broken or stuck piston ring Worn piston pin and hole at piston end of connecting rod
	Sound is not reduced if each fuel injector connector is disconnected in turn. (NOTE*)	<ul style="list-style-type: none"> Unusually worn valve lifter Worn cam gear Worn camshaft journal bore in crankcase
Squeaky sound	—	<ul style="list-style-type: none"> Insufficient generator lubrication
Rubbing sound	—	<ul style="list-style-type: none"> Defective generator brush and rotor contact
Gear scream when starting engine	—	<ul style="list-style-type: none"> Defective ignition starter switch Worn gear and starter pinion
Sound like polishing glass with a dry cloth	—	<ul style="list-style-type: none"> Loose drive belt Defective water pump shaft
Hissing sound	—	<ul style="list-style-type: none"> Loss of compression Air leakage in air intake system, hoses, connections or manifolds
Timing belt noise	—	<ul style="list-style-type: none"> Loose timing belt Belt contacting case/adjacent part
Valve tappet noise	—	<ul style="list-style-type: none"> Incorrect valve clearance

NOTE*:

When disconnecting the fuel injector connector, Malfunction Indicator Light (CHECK ENGINE light) illuminates and trouble code is stored in ECM memory.

Therefore, carry out the CLEAR MEMORY MODE <Ref. to EN(H4DOSTC)-35, OPERATION, Clear Memory Mode.> and INSPECTION MODE <Ref. to EN(H4DOSTC)-33, OPERATION, Inspection Mode.> after connecting the fuel injector connector.

ENGINE NOISE

MECHANICAL

MEMO: