

4. Camshaft

A: REMOVAL

1. RELATED PARTS

Remove timing belt, camshaft sprockets and related parts. <Ref. to 2-3a [W2A0].>

2. CAMSHAFT (LH)

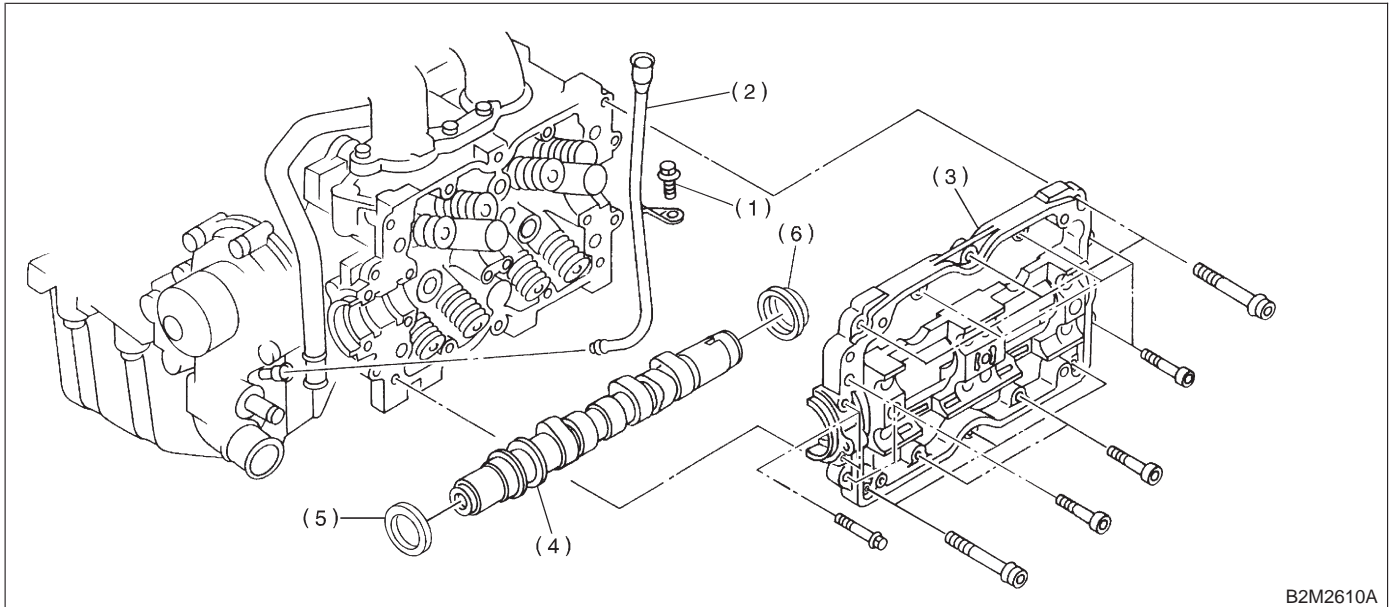

B2M2610A

- | | | |
|---------------------------|-------------------|--------------|
| (1) Bolt | (3) Camshaft cap | (5) Oil seal |
| (2) Oil level gauge guide | (4) Camshaft (LH) | (6) Plug |

1) Remove camshaft position sensor.

CAUTION:

Do not damage the camshaft position sensor.

- 2) Remove oil level gauge guide attaching bolt.
 - 3) Remove oil level gauge guide.
 - 4) Remove camshaft position sensor support.
 - 5) Remove camshaft cap.
- (1) Remove valve rocker assembly.
<Ref. to 2-3a [W3A0].>

(2) Remove bolts (a) through (b) in alphabetical sequence.

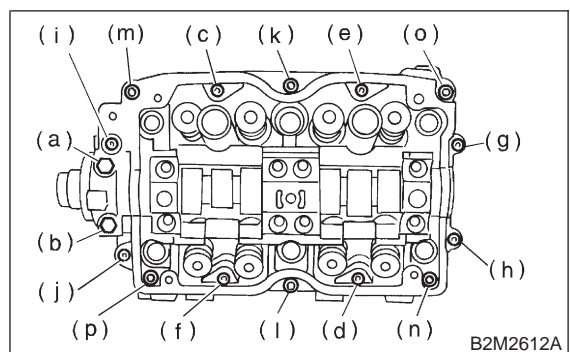

B2M2612A

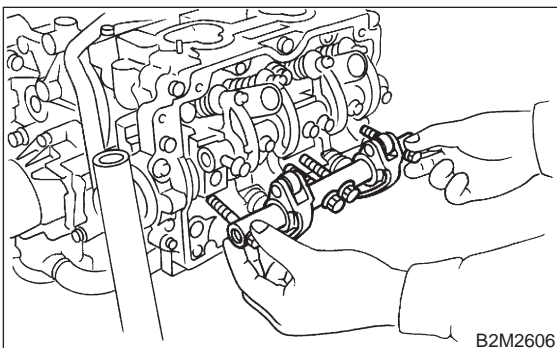

B2M2606

(3) Equally loosen bolts (c) through (j) all the way in alphabetical sequence.

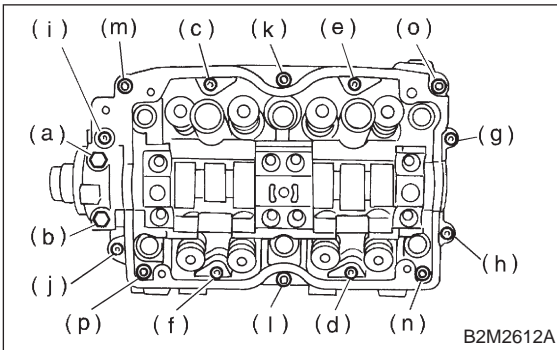

(4) Remove bolts (k) through (p) in alphabetical sequence using ST.

ST 499497000 TORX PLUS

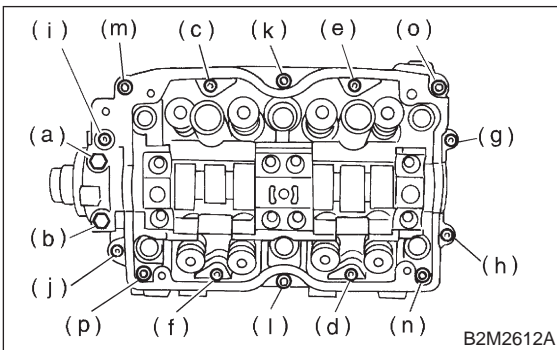

(5) Remove camshaft cap.

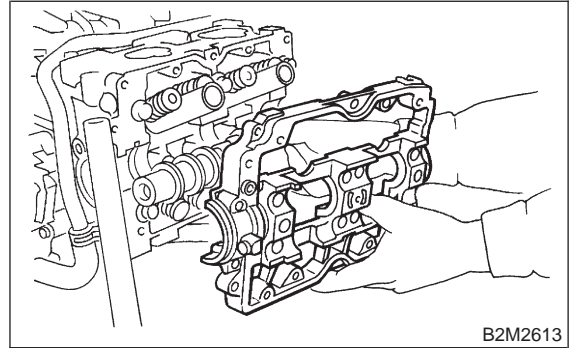

6) Remove camshaft (LH).

7) Remove oil seal.

8) Remove plug from rear side of camshaft (LH).

CAUTION:

- Do not remove oil seal unless necessary.
- Do not scratch journal surface when removing oil seal.

3. CAMSHAFT (RH)

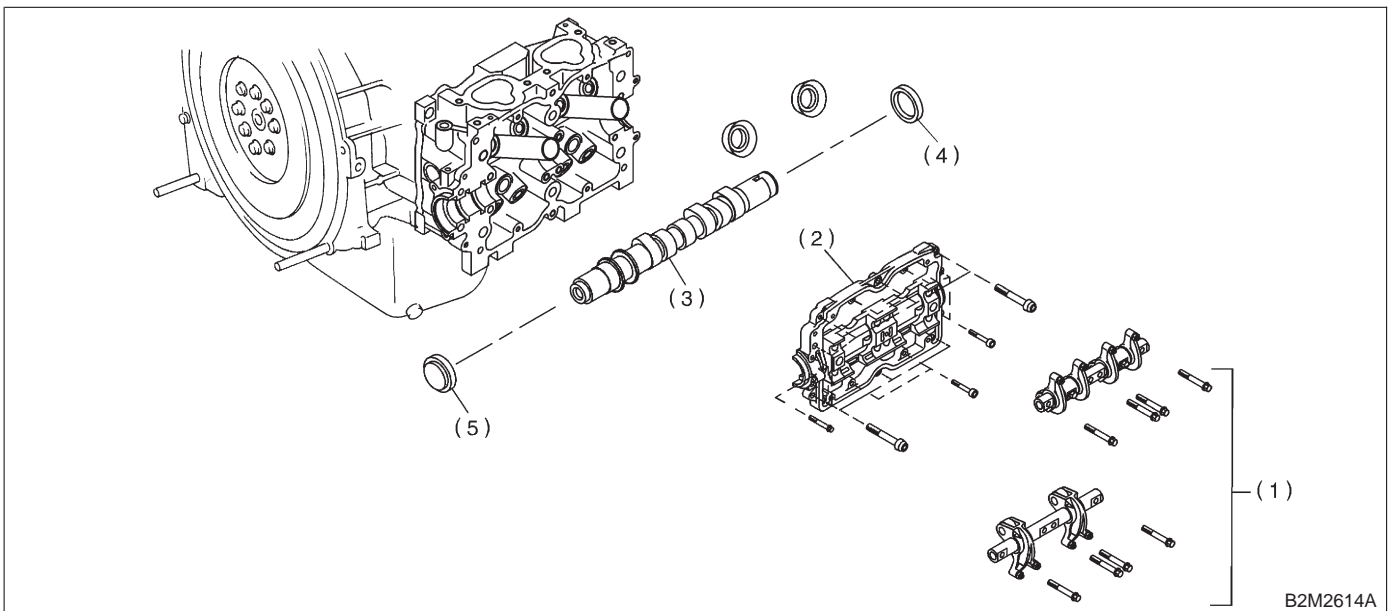

(1) Camshaft (RH)

(3) Valve rocker ASSY

(5) Plug

(2) Camshaft cap

(4) Oil seal

1) Remove camshaft cap.

(1) Remove valve rocker assembly RH.
<Ref. to 2-3a [W3A0].>

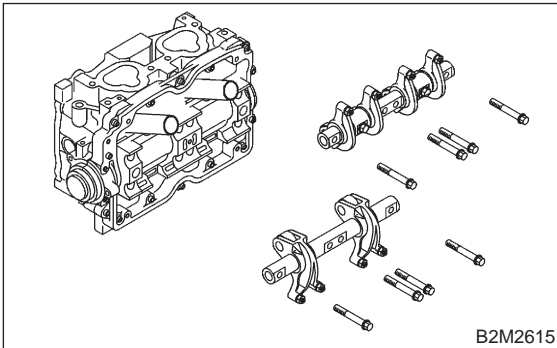

(2) Remove bolts (a) through (b) in alphabetical sequence.

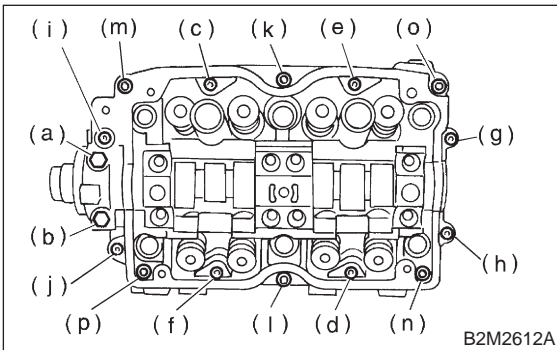

(3) Equally loosen bolts (c) through (j) all the way in alphabetical sequence.

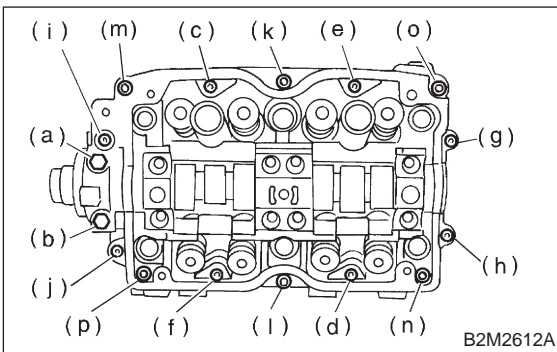

(4) Remove bolts (k) through (p) in alphabetical sequence using ST.

ST 499497000 TORX PLUS

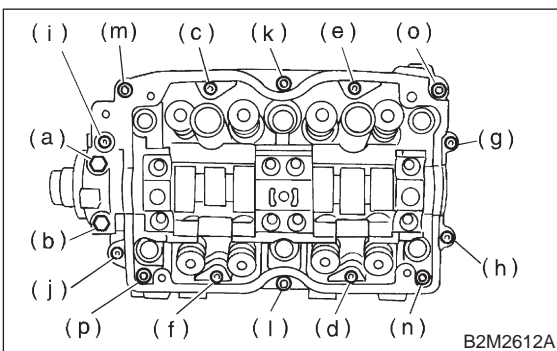

(5) Remove camshaft cap.

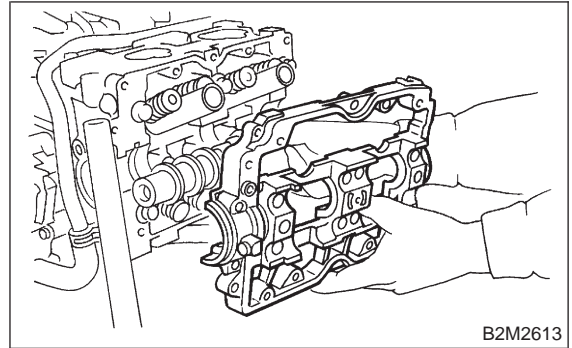

- 2) Remove camshaft (RH).
- 3) Remove oil seal.
- 4) Remove plug from rear side of camshaft (RH).

CAUTION:

- Do not remove oil seal unless necessary.
- Do not scratch journal surface when removing oil seal.

B: INSPECTION

1. CAMSHAFT

- 1) Measure the bend, and repair or replace if necessary.

Limit:

0.020 mm (0.0008 in)

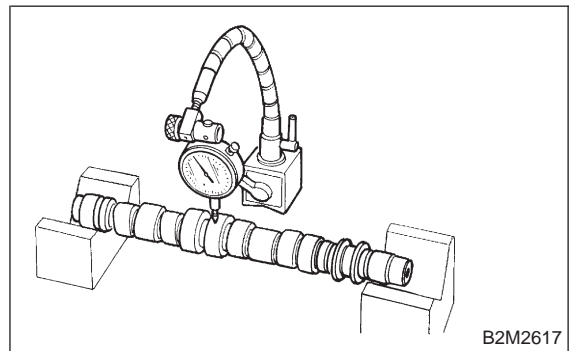

- 2) Check journal for damage and wear. Replace if faulty.

3) Measure outside diameter of camshaft journal and inside diameter of cylinder head journal, and determine the difference between the two (= oil

clearance). If oil clearance exceeds specifications, replace camshaft or cylinder head as necessary.

		Unit: mm (in)
Clearance at journal	Standard	0.055 — 0.090 (0.0022 — 0.0035)
	Limit	0.118 (0.0046)
Camshaft journal O.D.		31.928 — 31.945 (1.2570 — 1.2577)
Journal hole I.D.		32.000 — 32.018 (1.2598 — 1.2605)

4) Check cam face condition; remove minor faults by grinding with oil stone. Measure the cam height H; replace if the limit has been exceeded.

Cam height: H

Item	Unit: mm (in)	
	Standard	Limit
Intake	34.00 — 38.782 (1.3386 — 1.5268)	33.84 (1.3323)
Exhaust	34.00 — 39.307 (1.3386 — 1.5475)	33.84 (1.3323)

Cam base circle diameter A:
IN: 27.5 mm (1.083 in)
EX: 27.0 mm (1.063 in)

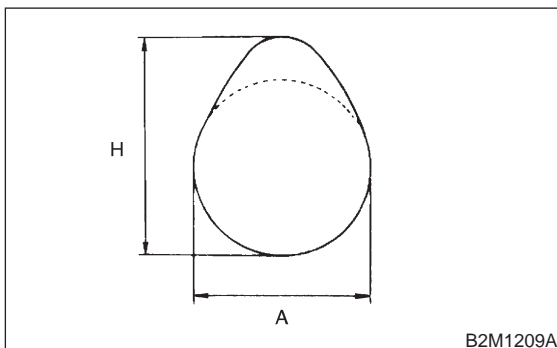

2. CAMSHAFT SUPPORT

Measure the thrust clearance of camshaft with dial gauge. If the clearance exceeds the limit, replace camshaft support.

Standard:

0.030 — 0.090 mm (0.0012 — 0.0035 in)

Limit:

0.11 mm (0.0043 in)

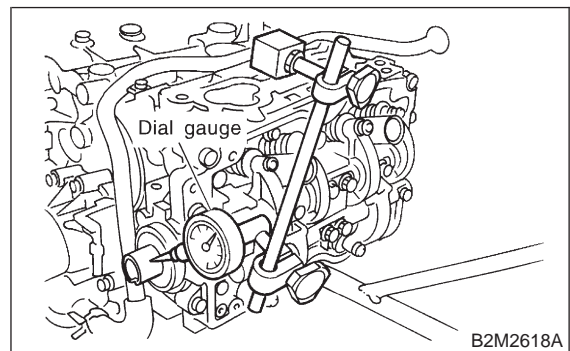

C: INSTALLATION

1. CAMSHAFT (LH)

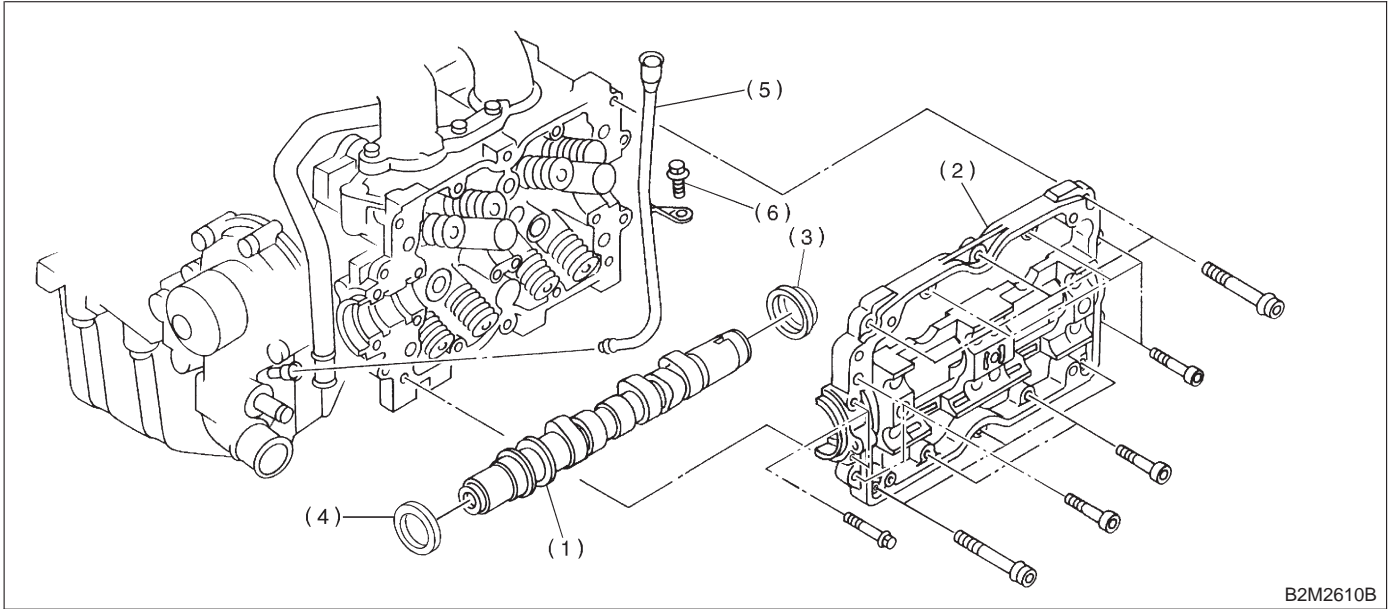

B2M2610B

(1) Camshaft (LH)

(3) Plug

(5) Oil level gauge guide

(2) Camshaft cap

(4) Oil seal

(6) Bolt

1) Apply a coat of engine oil to camshaft journals and install camshaft (LH).

2) Install camshaft cap.

(1) Apply liquid gasket on the around of camshaft cap.

(2) Temporarily tighten bolts (g) through (j) in alphabetical sequence.

Liquid gasket:

THREE BOND 1280B (Part No. 0029431130)

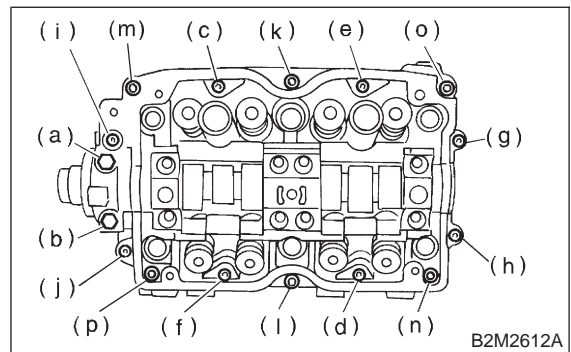

B2M2612A

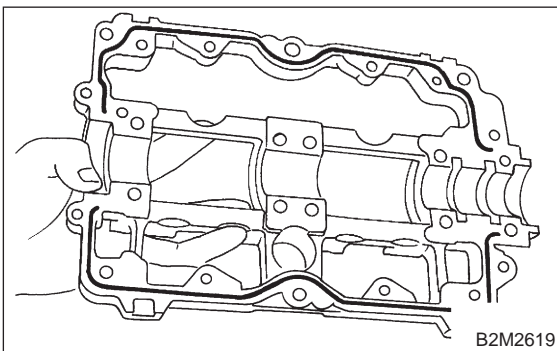

B2M2619

(3) Install valve rocker assembly.

<Ref. to 2-3a [W3E0].>

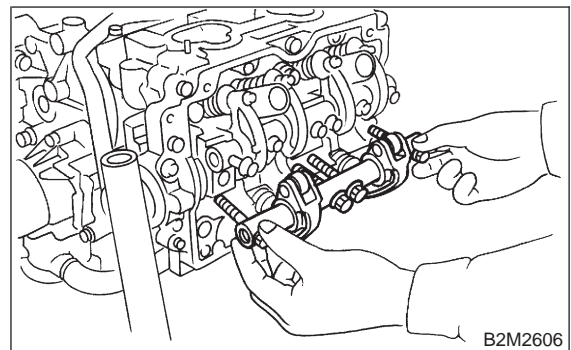

B2M2606

(4) Tighten bolts (a) through (h) in alphabetical sequence.

Tightening torque:

25±2 N·m (2.5±0.2 kg·m, 18.1±1.4 ft·lb)

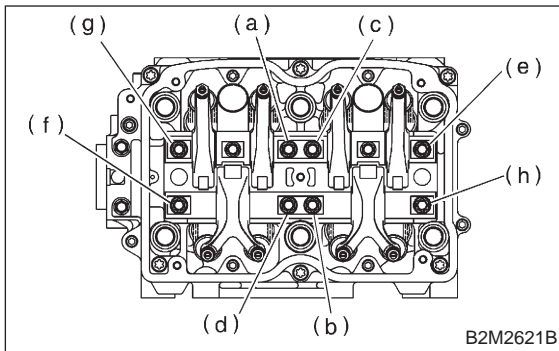

(5) Tighten TORX bolts (i) through (n) in alphabetical sequence using ST.
ST 499497000 TORX PLUS

Tightening torque:

18±2 N·m (1.8±0.2 kg·m, 13.0±1.4 ft·lb)

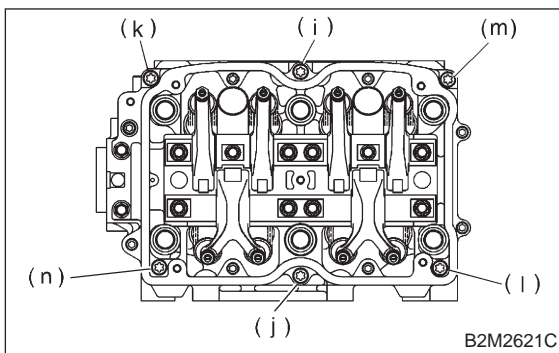

(6) Tighten bolts (o) through (v) in alphabetical sequence.

Tightening torque:

10±2 N·m (1.0±0.2 kg·m, 7.2±1.4 ft·lb)

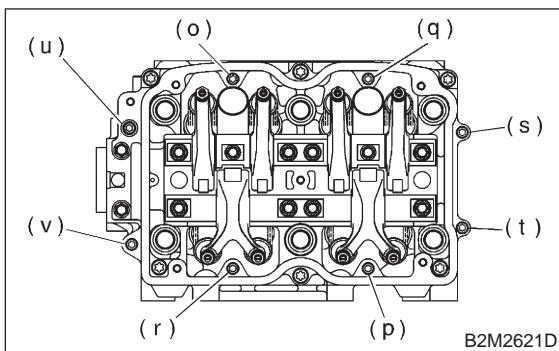

(7) Tighten bolts (w) through (x) in alphabetical sequence.

Tightening torque:

10±2 N·m (1.0±0.2 kg·m, 7.2±1.4 ft·lb)

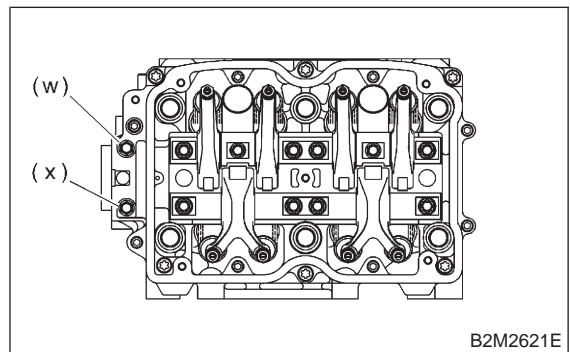

3) Apply a coat of grease to oil seal lips and install oil seal (A) on camshaft using ST1 and ST2.

CAUTION:

Use a new oil seal.

- ST1 499597000 OIL SEAL GUIDE
- ST2 499587500 OIL SEAL INSTALLER

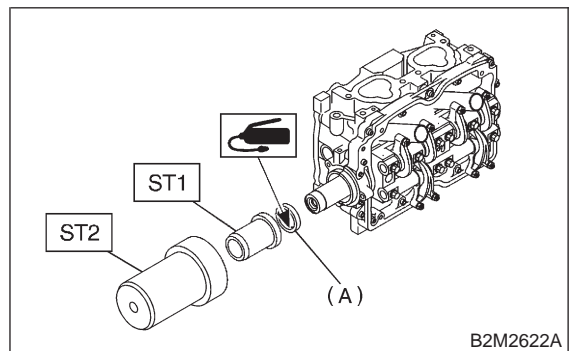

4) Install plug using ST.

ST 499587100 OIL SEAL INSTALLER

5) Install oil level gauge guide.

6) Install camshaft position sensor support.

2. CAMSHAFT (RH)

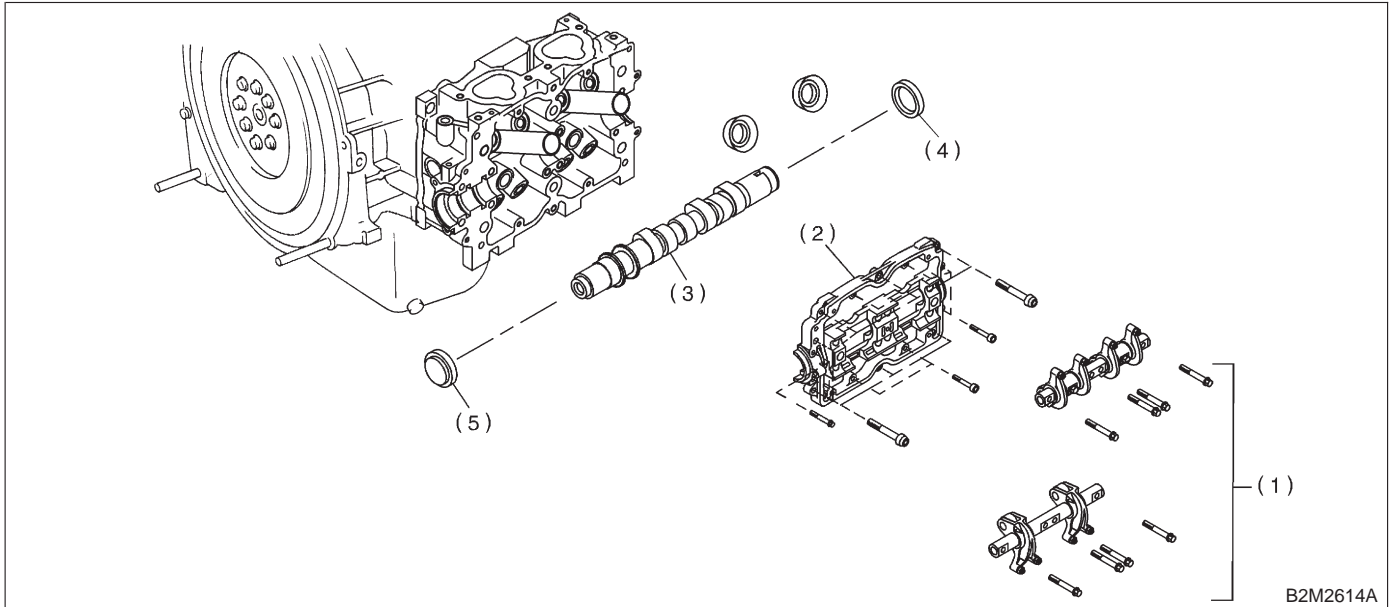

- (1) Camshaft support (RH)
- (2) O-ring
- (3) Camshaft (RH)
- (4) Oil seal
- (5) Plug

- 1) Apply a coat of engine oil to camshaft journals and install camshaft (RH).
- 2) Install camshaft cap.
 - (1) Apply liquid gasket on the around of camshaft cap.

- (2) Temporarily tighten bolts (g) through (j) in alphabetical sequence.

Liquid gasket:
THREE BOND 1280B (Part No. 0029431130)

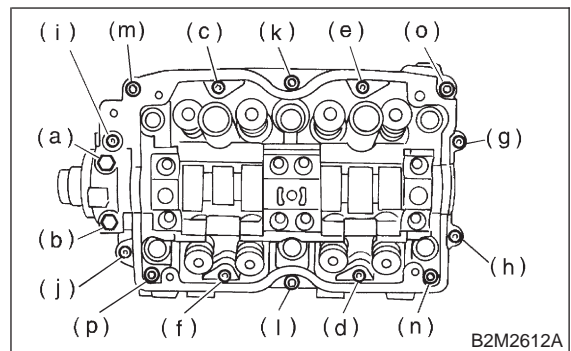
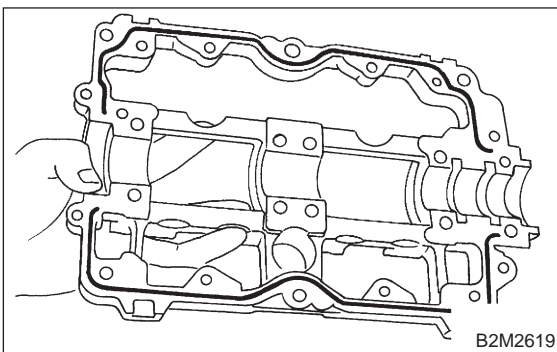

- (3) Install valve rocker assembly. <Ref. to 2-3a [W3E0].>

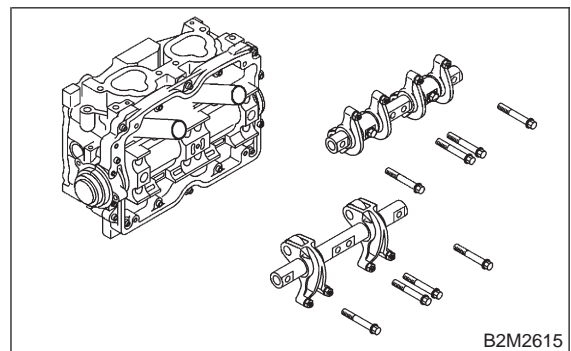

(4) Tighten bolts (a) through (h) in alphabetical sequence.

Tightening torque:

25±2 N·m (2.5±0.2 kg·m, 18.1±1.4 ft·lb)

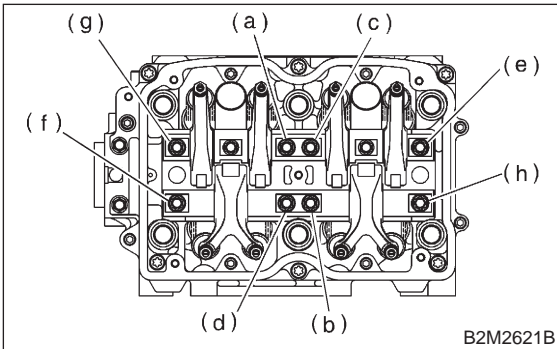

(5) Tighten TORX bolts (i) through (n) in alphabetical sequence using ST.

ST 499427000 TORX PLUS

Tightening torque:

18±2 N·m (1.8±0.2 kg·m, 13.0±1.4 ft·lb)

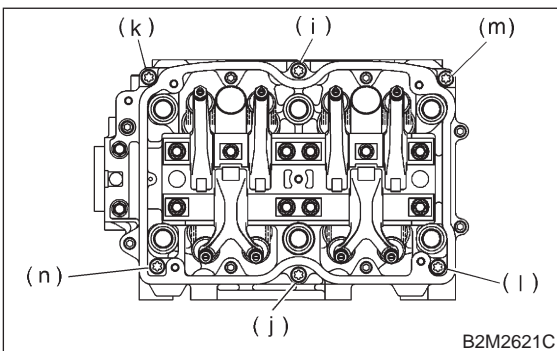

(6) Tighten bolts (o) through (v) in alphabetical sequence.

Tightening torque:

10±2 N·m (1.0±0.2 kg·m, 7.2±1.4 ft·lb)

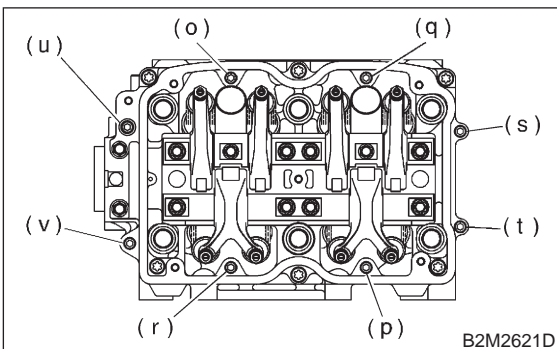

(7) Tighten bolts (o) through (p) in alphabetical sequence.

Tightening torque:

10±2 N·m (1.0±0.2 kg·m, 7.2±1.4 ft·lb)

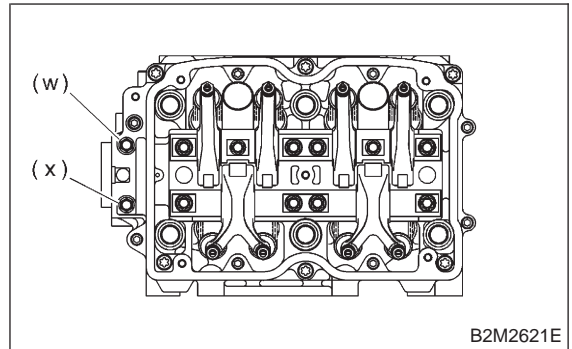

3) Apply a coat of grease to oil seal lips and install oil seal (A) on camshaft using ST1 and ST2.

CAUTION:

Use a new oil seal.

- ST1 499597000 OIL SEAL GUIDE
- ST2 499587500 OIL SEAL INSTALLER

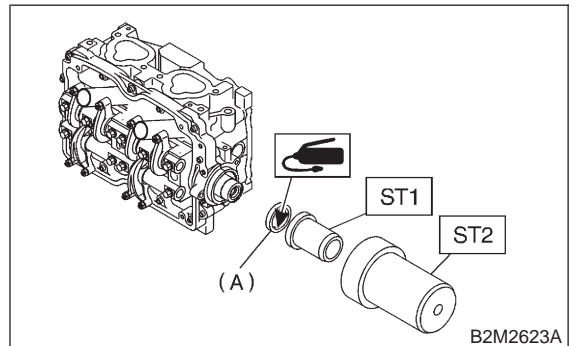

4) Install plug using ST.
ST 499587100 OIL SEAL INSTALLER

3. RELATED PARTS

Install timing belt, camshaft sprockets and related parts.

<Ref. to 2-3a [W2C0].>