

Subaru EJ22/EJ25
 Vanagon Conversion ECU Mil
 Light Wiring
 BCWeide - 2011

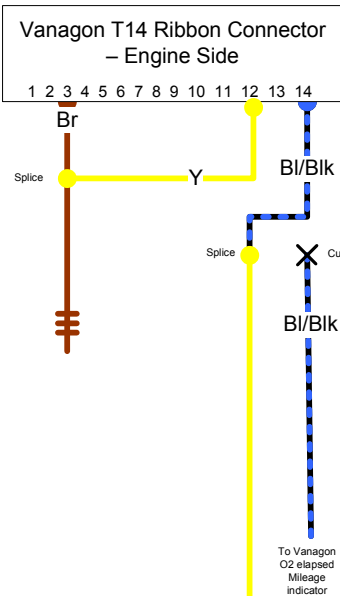

1992-94 Subaru EJ22 - D19
 1995 Subaru = B84-58
 2001-03 Subaru - B134-11
 2004 Subaru = B15

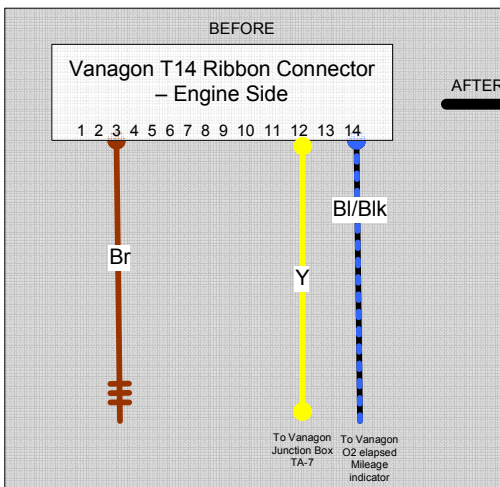
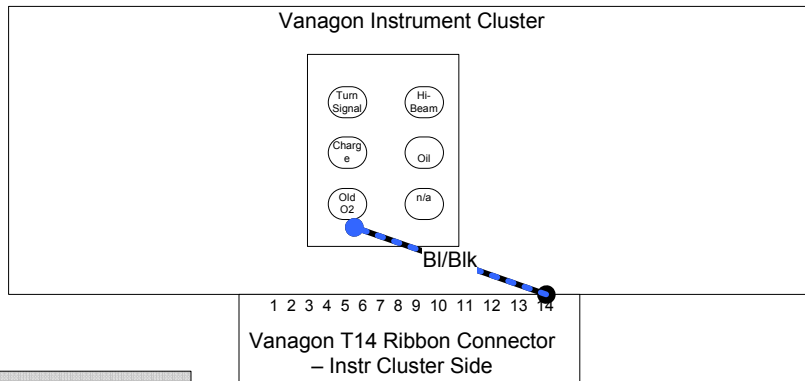
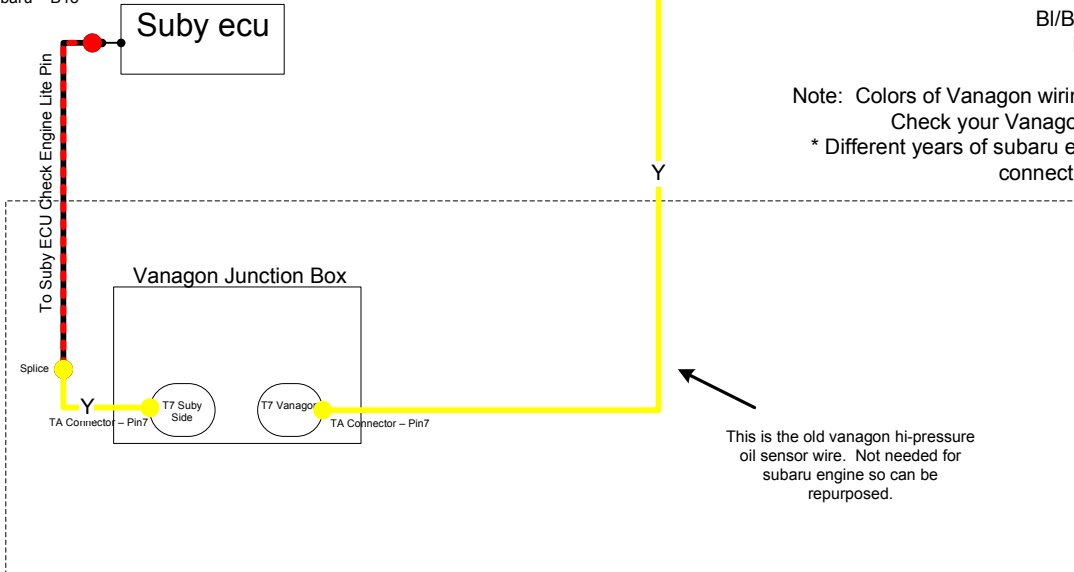

Displays one method of using the old, unused vanagon hi-pressure oil wire to connect the subaru ecu mil light to the vanagon instrument cluster to enable using the old vanagon o2 sensor light to instead be used as subaru engine check engine light.

Y = Yellow
 BI/Blk = Blue Black
 Br = Brown

Note: Colors of Vanagon wiring may differ between years of Vanagon. Check your Vanagon wiring schematic to be sure.

* Different years of subaru ecu's may also use a different pin out to connect the ecu code light.

This is the old vanagon hi-pressure oil sensor wire. Not needed for subaru engine so can be repurposed.